



15MM BUILDING SYSTEM GUIDE

TABLE OF CONTENTS

1	INTRODUCTION.....	4
1.1	ABOUT REV ROBOTICS.....	4
1.2	HOW TO USE THIS GUIDE.....	4
1.3	15MM EXTRUSION SYSTEM BASICS	4
2	SYSTEM COMPONENTS	5
2.1	EXTRUSION	5
2.2	BRACKETS.....	5
2.2.1	Bracket Features	5
2.2.2	All Bracket Types	6
2.2.3	Variable Angle Bracket.....	7
2.2.4	Indexable Motion Bracket	7
2.3	BEARINGS	8
2.4	JOINTS	10
2.4.1	Constructing Joints	10
2.4.2	Corner Bracket Joint Examples.....	11
2.5	HARDWARE	11
2.5.1	Nuts and Bolts	11
2.5.2	Drop-in Bolts	11
2.5.3	5mm Hex Shaft.....	12
2.5.4	Shaft Collars and Spacers	12
2.6	ADAPTERS.....	14
2.6.1	High Strength Hex Hub	14
2.6.2	Servo Adapters	15
2.7	MOTION COMPONENTS	16
2.8	WHEELS	17
2.8.1	Omni Wheels.....	17
2.8.2	All Wheels.....	18
2.9	SPROCKETS AND CHAIN.....	19
2.9.1	Chain Tension	21
2.9.2	Anatomy of Chain	21
2.9.3	Custom Length Chain	22
2.9.4	Master Links	22
2.9.5	All Sprockets	23
2.10	GEARS	24

2.10.1	Correct Gear Spacing	24
2.10.2	All Gears	25
3	BASIC BUILDING GUIDE	25
3.1	ASSEMBLY TECHNIQUES	25
3.1.1	BRACKET ASSEMBLY METHOD.....	26
3.1.2	BOLT-FIRST METHOD.....	27
3.1.3	ACCESS-HOLE METHOD	27
3.1.4	DROP-IN BOLT METHOD.....	28
3.1.5	END-TAPPED EXTRUSION METHOD.....	28
3.2	DRIVE TRAIN GUIDE	29
3.2.1	DROP CENTER 6-WHEEL DRIVE.....	29
3.2.2	Geared Drive Train	29
3.2.3	Sprocket and Chain Drive Train.....	30
3.3	ARM GUIDE.....	32
3.3.1	SIMPLE ARMS	32
3.4	COMPATABILITY GUIDE	32
4	ALL COMPONENTS (1:1 Scale)	36
4.1	GEARS (1:1).....	37
4.2	SPROCKETS (1:1)	38
4.3	TRACTION WHEELS (1:1).....	39
4.4	BRACKETS (1:1).....	40
4.5	PILLOW BLOCKS (1:1).....	42
4.6	BEARINGS (1:1)	42
4.7	SPACERS (1:1).....	42
4.8	Adapters and Collars (1:1)	42

1 INTRODUCTION

1.1 ABOUT REV ROBOTICS

Everyone at REV Robotics is also personally involved with STEM Education and FIRST Robotics teams and have been for years, some of us are even FIRST Alumni. When designing products for teams, these experiences are at the forefront of our minds. REV Robotics is always working to create products which help more teams innovate, compete, and win. We always love to hear from our customers, so please use the “Contact Us” link on our website (www.revrobotics.com) to drop us a line!

1.2 HOW TO USE THIS GUIDE

Feel free to pick out specific sections of interest and read those, there is no need to consume this document in any sequential method.

This guide is intended to be an introduction to the REV Robotics 15mm Extrusion Building System. Building with extrusion can be a very different kind of thought process than with the fix pitched systems most people are familiar with. Fixed pitch based systems have a fixed pattern of holes and everything must mount into these fixed hole locations so that everything is spaced on a multiple of the pitch. With extrusion, building is all about being able to adjust mounting positions infinitely by sliding brackets mounted into channels. We think that the easier it is to adjust your design the easier it is to iterate and improve that design.

This guide aims to introduce the reader to all of the components in the 15mm Extrusion System and provide basic building techniques and example solutions to common challenges faced in competitive robotics. There are already lots of examples in this document, but we’re committed to continuing to add content to keep making it more accessible for people to build with REV.

1.3 15MM EXTRUSION SYSTEM BASICS

It is possible to use this system to build a complete robot or combine it with other systems and custom parts to create your design. Our philosophy when creating this system was to be as compatible as we could with the existing hardware most teams have, without sacrificing the quality of the components in our system.

For the REV Building system only some basic tools are needed. Please see Table 1 for recommendations.

Table 1: Recommended Tool List

Tool	Required	Use
5.5mm Nut Drive	Yes	M3 Hardware
5.5mm Combination Wrench	Yes	M3 Hardware
1.5mm Allen Wrench	Optional	M3 Shaft Collars
Small Pliers	Optional	Working with Chain
Chain Breaker	Optional	Working with Chain
Hack Saw	Yes	Cutting Extrusion
Chop Saw	Optional	Cutting Extrusion
Band Saw	Optional	Cutting Extrusion
Diagonal/Flush Cutter	Optional	Trimming Brackets to Customize
File/Sandpaper	Optional	Trimming Brackets to Customize

2 SYSTEM COMPONENTS

2.1 EXTRUSION

Extrusion is 15mm x 15mm square profile clear anodized 6063-T5 Aluminum. Slots accept standard M3 hex-head bolts or nuts, rather than expensive t-nuts. The five-hole pattern on the end of the extrusion can be M3 tapped (Figure 1). The slots in the extrusion allow attached brackets to be slid and retightened to an infinite number of locations. This makes things like mating gears and tensioning chain easy. Fine system adjustments can occur at any point in the system development which helps foster an iterative design process.

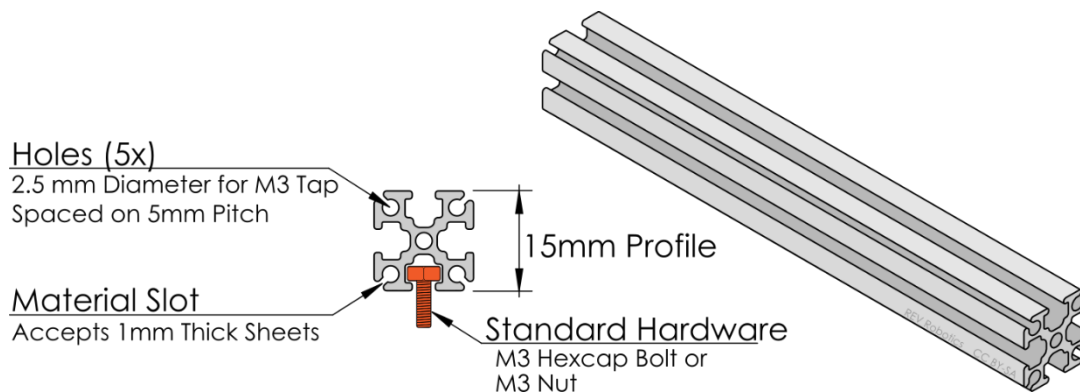

Figure 1: Extrusion and Cross-Section Details

2.2 BRACKETS

2.2.1 Bracket Features

Plastic brackets are nominally 3mm thick and made from molded nylon (PA66). Figure 2 lists key features of the Plastic Brackets for the REV Robotics 15mm Extrusion System. Check individual product CAD models for exact dimensions for each bracket.

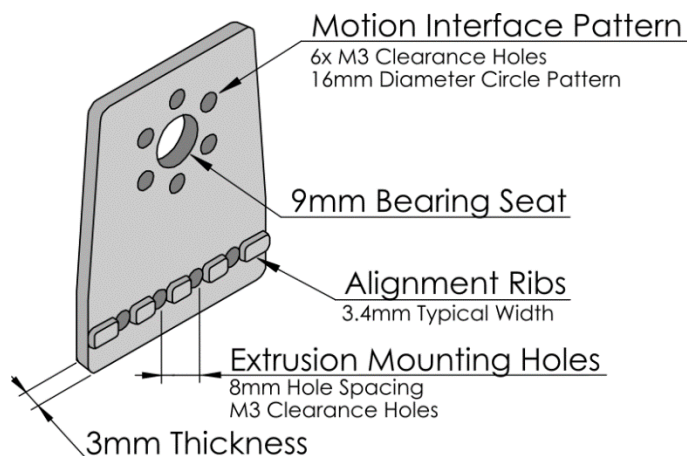

Figure 2: Motion Bracket Feature Details

Alignment Ribs: Protrusions on one side of the bracket seat into the extrusion channel and help align the bracket to the extrusion and add strength and rigidity to joints.

Extrusion Mounting Holes: M3 Mounting holes are on an 8mm pitch.

Bearing Seat: Brackets with a 9mm hole can be used to mate with any of the plastic bearings to support a shaft.

Motion Interface Mounting Pattern: Circular M3 hole pattern on a 16mm diameter is used to mount to REV Robotics shaft accessories.

2.2.2 All Bracket Types

Table 2 and Table 3 show all of the motion and construction brackets in the REV Robotics 15mm Plastic Building System.

Table 2: Motion Brackets

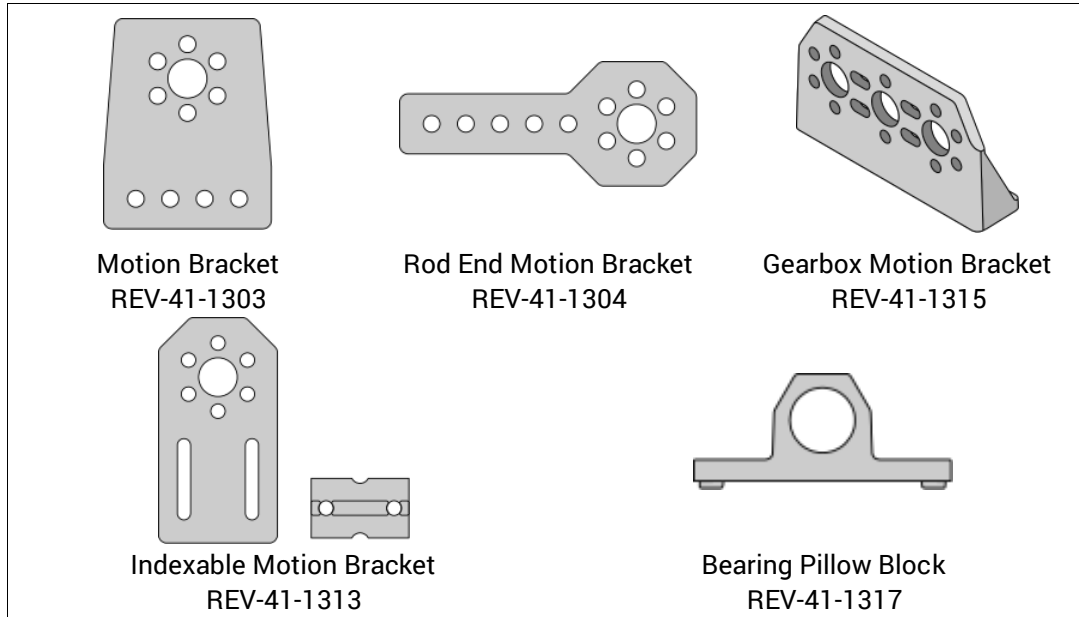
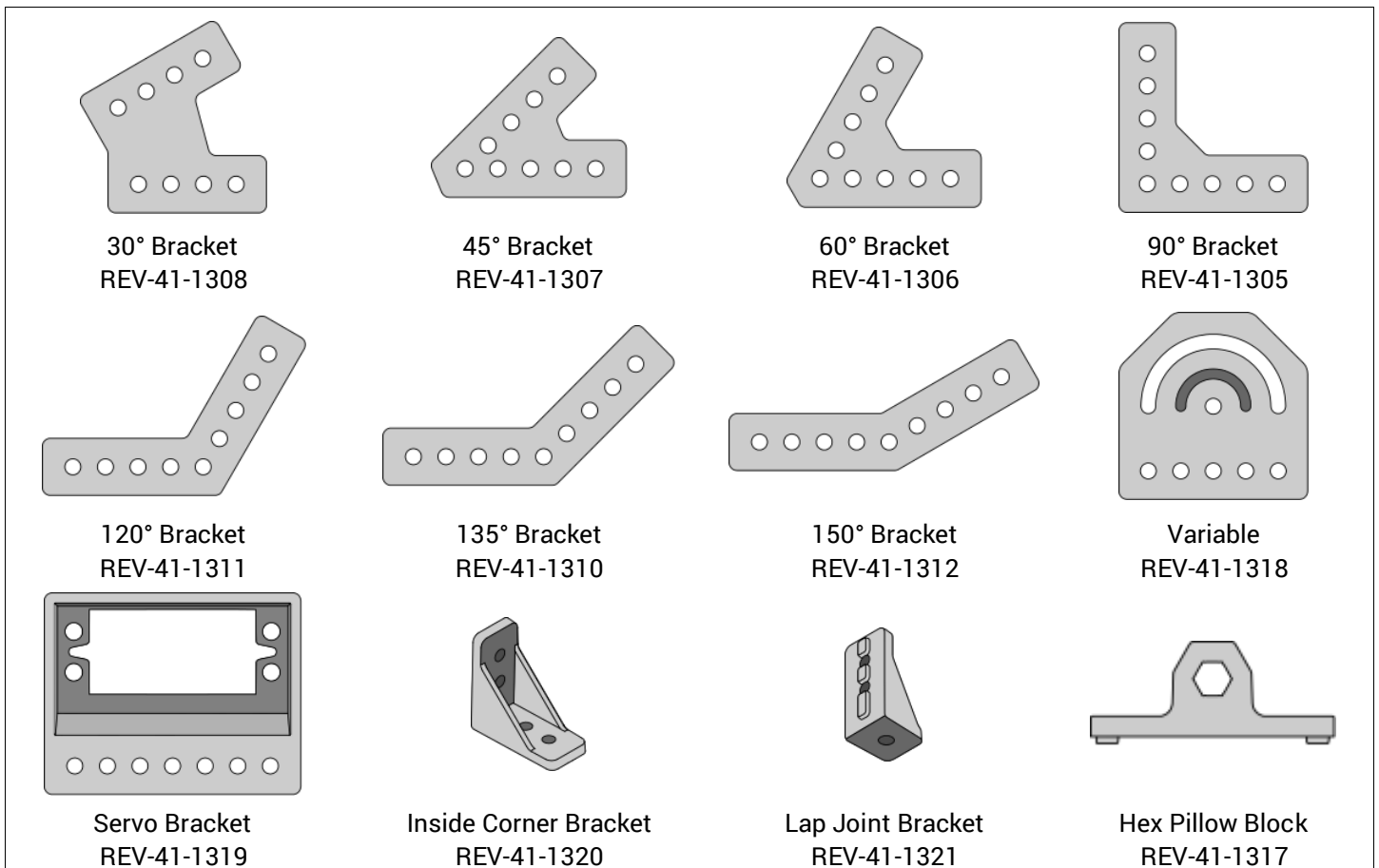

Table 3: Construction Brackets



The REV Robotics 15mm building system uses plastic nylon (PA66) molded pillow blocks. The bearing pillow block can be used with the long through-bore or end cap bearings to provide a low friction shaft support. The hex pillow block directly interfaces with a 5mm shaft which can be used to drive a light duty arm or as a dead axle support.

2.2.3 Variable Angle Bracket

The variable angle bracket is a special kind of construction bracket which allows 2 pieces of extrusion to be mounted together at any angle from 0-180° (Figure 3). For additional strength, after the ideal angle has been set, miter the end of the extrusion which will be connected using the arced slot and drill a hole along the alignment mark arc so that it lines up with the extrusion channel and add another bolt to fix the angle.

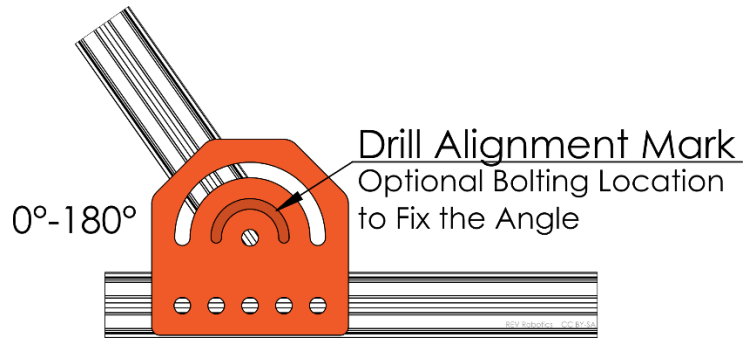

Figure 3: Adjustable Angle Bracket Example

2.2.4 Indexable Motion Bracket

The Indexable Motion Bracket is a specialized version of the Motion Bracket. This bracket is made up of two pieces: the smaller piece has alignment ribs and fits onto the extrusion, while the larger piece has a motion interface pattern and a bearing seat (Figure 4). On the inside face, where these brackets meet is a fine sawtooth pattern which mesh when they are bolted together to hold the shaft offset. To adjust the offset, loosen the bolts and adjust as needed, retighten with the teeth fully engaged to resecure (Figure 5).

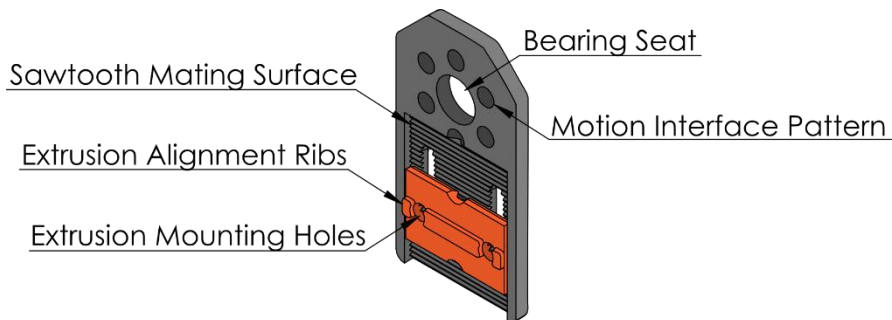

Figure 4: Indexable Motion Bracket

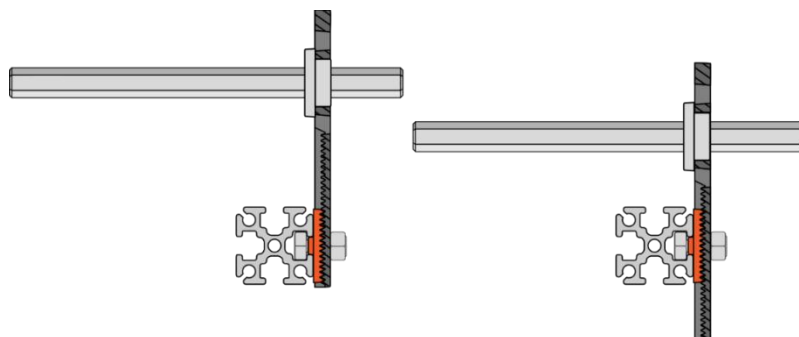

Figure 5: Shaft Offset Using an Indexable Bracket

2.3 BEARINGS

The REV Robotics 15mm Extrusion Building System uses plastic acetal (Delrin/POM) molded bearings. These bearings have a maximum 9mm outer diameter (OD) which fit inside the 9mm inner diameter (ID) hole in the all the motion brackets (Figure 6).

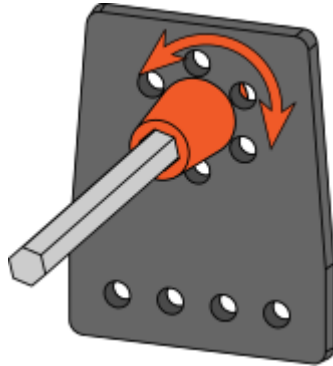

Figure 6: Plastic Bearing in a Motion Bracket

These Delrin bearings provide stable, low friction axle support in our nylon brackets. The two materials were carefully chosen because they have a very low coefficient of friction and are also incompatible materials, meaning that they will not stick together under extreme heat. REV Robotics Bearings come in three varieties (Table 4).

Table 4: Bearings



End cap bearings are closed on one end, so when these bearings are placed on both ends of a shaft and fit into motion brackets the shaft is free to rotate but is fully constrained laterally (sideways).

Short Through-bore Bearings are low profile pass through bearings intended to seat directly into any of the motion brackets. These low-profile bearings have a 3mm contact surface which makes them flush with one side of the motion plate. Shaft collars are recommended to laterally constrain the shaft.

Long Through-bore Bearings are full depth bearings which can be used with any of the motion brackets or the bearing pillow block. Unlike the end cap bearing, because a shaft can pass through this bearing it can be used with the bearing pillow block to have a pivot between two fixed shaft ends. Shaft collars are recommended to laterally constrain the shaft.

There are a number of different bearing, shaft collar, and motion bracket combinations that are recommended. See Figure 7 for a visual representation of some of the recommended combinations.

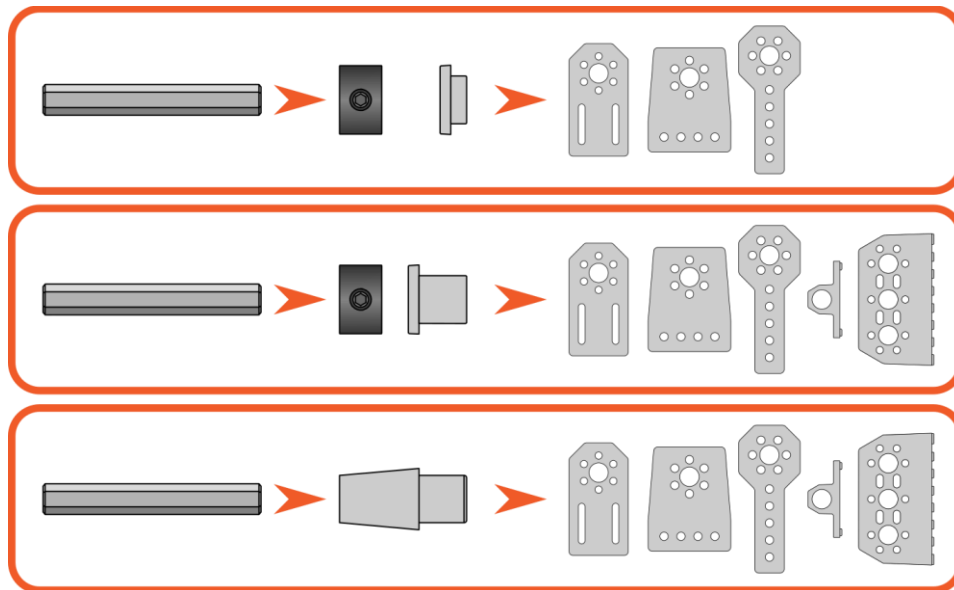

Figure 7: Bearing Assembly Combination Recommendations

Figure 8 - Figure 11 shows several possible combinations for bearings, motion brackets, and pillow blocks. In these figures the brackets are all depicted as facing “up” but brackets can also point “down” just as well.

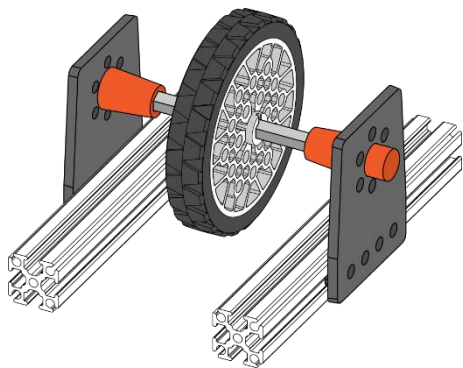

Figure 8: Motion Brackets and End Cap Bearings

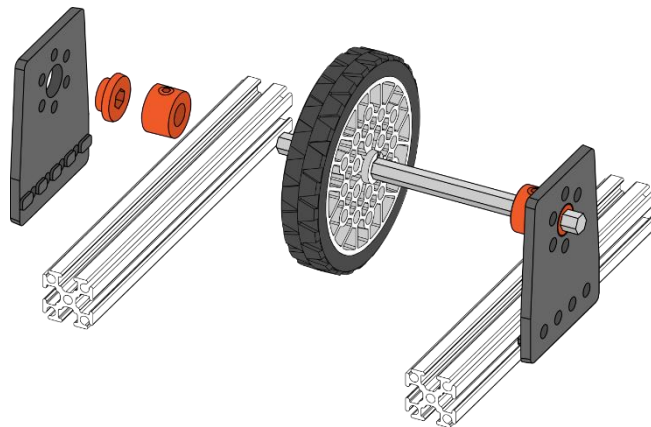

Figure 9: Motion Bracket and Short Through bore Bearings

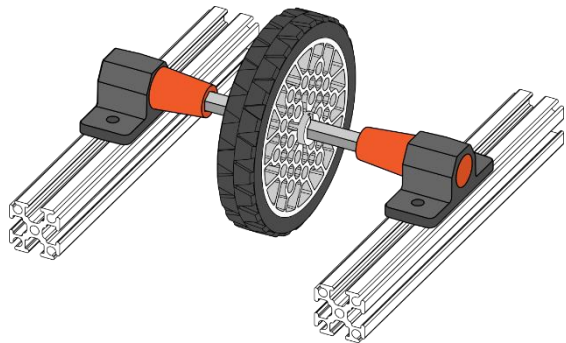

Figure 10: Pillow Blocks and End Cap Bearings

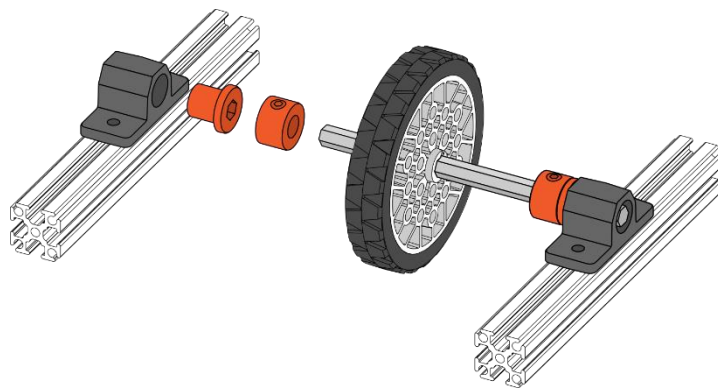

Figure 11: Pillow Blocks and Long Through bore Bearings

2.4 JOINTS

2.4.1 Constructing Joints

In most cases joints should have at least two sides joined with brackets for strength and stability. Commonly this involves taking two of the same kind of bracket and sandwiching the pieces of extrusion (Figure 12), but this can also be two different kinds of brackets such as a 90 Degree Bracket and an Inside Corner Bracket installed on the same corner.

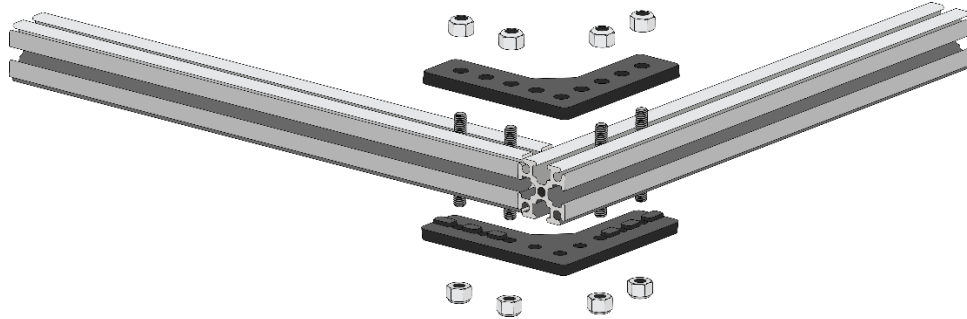

Figure 12: Install Brackets on Both Sides of the Joint

When using brackets to connect extrusion, the joint will be much stronger if the end of the extrusion is beveled (cut at an angle) so that the end will sit flush with the face of the adjoining extrusion (Figure 13).

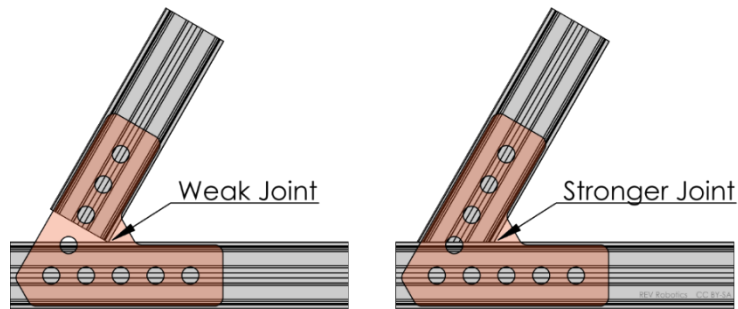

Figure 13: Extrusion with Beveled Joint

Different bracket angles can be combined to make structures (Figure 14). The joints in this example are all beveled to sit flush against the adjoining extrusion.

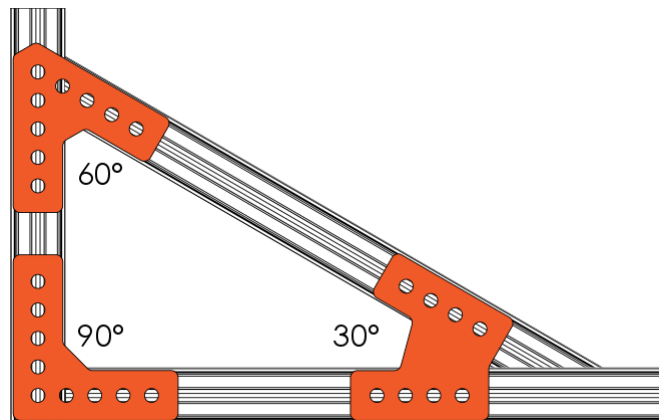

Figure 14: Combine Angled Brackets to Create Structures

2.4.2 Corner Bracket Joint Examples

There are three main ways to create extrusion joints that are at 90 degrees (Figure 15). The most common is the 90° bracket which mates to pieces of extrusion at 90° in the same plane. The second is an inside corner bracket is functionally equivalent to the 90° bracket. The third type is called a lap joint bracket which allowed to pieces of extrusion to “overlap.”

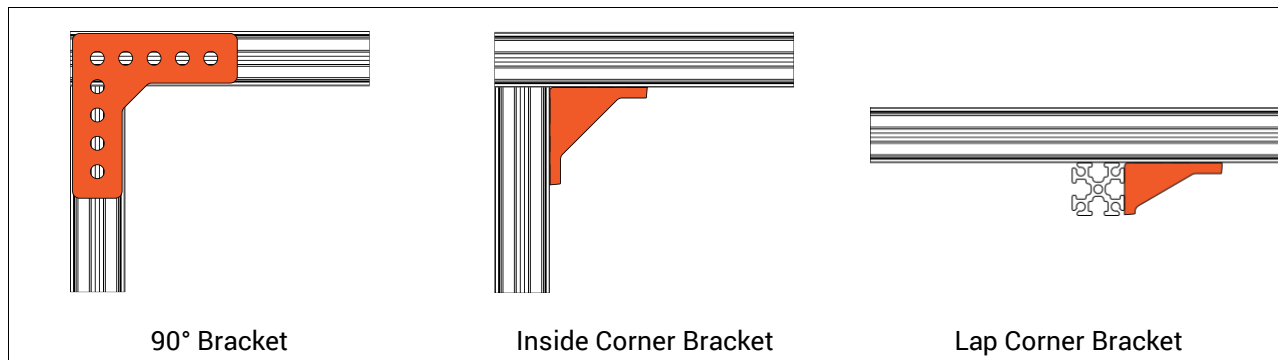

Figure 15: Corner Bracket Examples

2.5 HARDWARE

2.5.1 Nuts and Bolts

The REV Robotics 15mm Extrusion Building System is intended to be used with all M3 hardware (Figure 16). M3 hex cap bolts, nylon-insert lock nuts (“Nyloc”), and plain nuts are all readily available online and at many big box stores. Be sure to use quality hardware because low quality hardware will not perform as well as it is often made from softer materials which can round out in the extrusion when tightened.

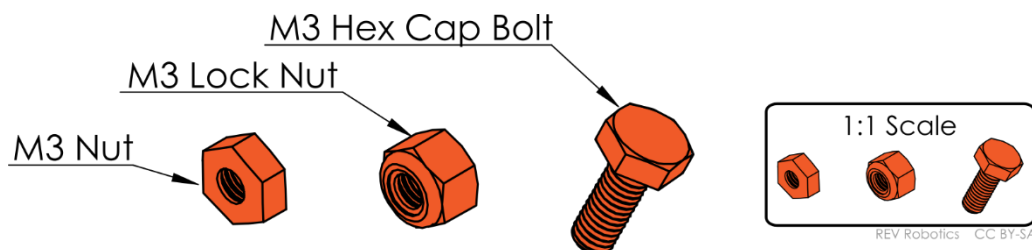

Figure 16: M3 Hardware

M3 hex cap bolts inserted into the extrusion and M3 nylon-insert nuts on the outside is the recommended “stud up” building orientation. The stud-up method doesn’t require precise bolt lengths and is compatible with locking nuts. Regular M3 Nuts will fit in the extrusion channel, but nylon-insert nuts will not. If attaching plastic brackets to the extrusion in the “stud down” orientation, be sure to use an appropriate length bolt with plain nuts in the channel.

2.5.2 Drop-in Bolts

Drop-in bolts have a modified head profile which allow the head to drop into the extrusion channel and then be tightened in place (Figure 17). This is a big advantage when modifying an existing design because new brackets can be added to any extrusion location— unlike standard hex cap bolts which must have access to an open end of extrusion so the heads can be slid into the channel from the edge. These assembly techniques are discussed in more detail in the [ASSEMBLY TECHNIQUES](#) section.

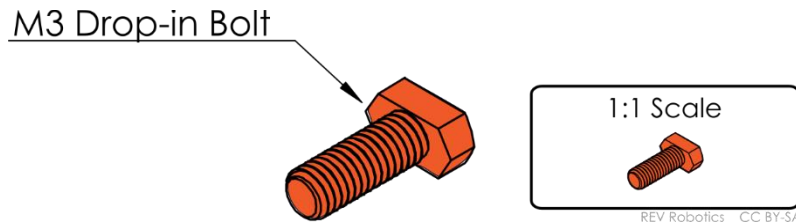

Figure 17: M3 Drop-in Bolt

2.5.3 5mm Hex Shaft

The REV Robotics 15mm building system is built around a 5mm hex shaft. Using a hex shaft to transmit torque in the system removes the need for set screws, which can loosen over time and can damage shafts so that they become useable. REV Robotics Hex Shafts are precision ground 5mm stainless steel and fits snugly in all other REV hex drive components (Figure 18).

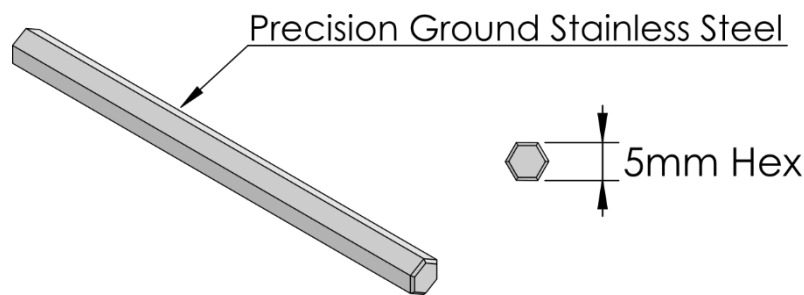

Figure 18: Stainless Steel 5mm Hex

REV Robotics Hex Shafts come in four lengths, 75mm (REV-41-1347), 90mm, 135mm (REV-41-1347) and 400mm (REV-41-1362). For high load applications it is recommended to use the REV precision shaft, stack multiple gears or sprockets in parallel, or use the metal hex hub adaptor (REV-41-1362) to increase strength.

2.5.4 Shaft Collars and Spacers

Shaft collars are used to prevent lateral (sideways/sliding) movement of a shaft, or an item on the shaft. A shaft collar is a hollow cylinder with one more set screws which tighten towards its center and an inner dimension (ID) that is just slightly larger than the shaft it is being used on (Figure 19). Since shaft collars are used to prevent lateral shaft movement they are often used in place of shaft spacers.

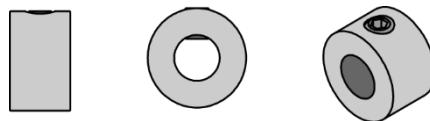

Figure 19: 6mm Shaft Collar

To use the shaft collar, slide it onto the hex shaft and rotate it until a flat side is facing the setscrew (Figure 20). Adjust the collar to the desired location and use a 1.5mm Allen wrench to tighten the included set screw snugly against the shaft. A small amount of a thread locker product, like Loctite Blue, can be used if desired. Most standard 6mm ID shaft collars can be used on the REV Robotics 5mm hex shaft, but the REV Robotics shaft collar is customized with a M3 thread so a standard hex cap bolt can be used instead of the supplied set screw.

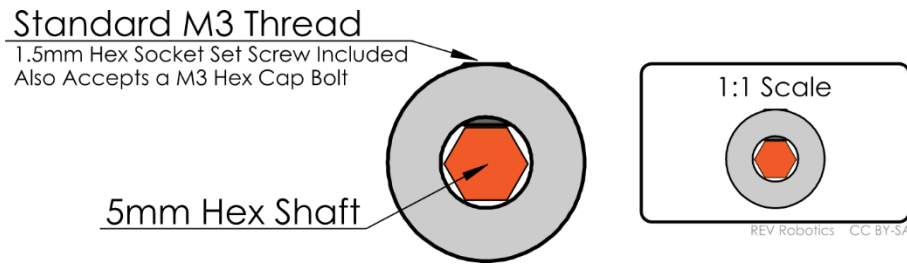

Figure 20: Shaft Collar Tightened on a Hex Shaft

The REV Robotics shaft collar has a 6mm inside diameter and is customized with a M3 thread so a standard hex cap bolt can be used instead of the supplied set screw (Figure 21).

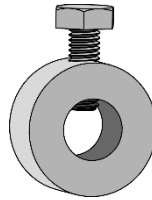

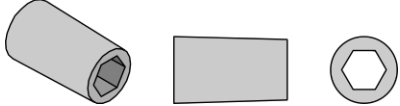

Figure 21: Shaft Collar with Standard M3 Hex Cap Fastener

Spacers for the 15mm building system have a 5mm hex center, are made of Delrin, and come in 3 lengths (Table 5). Spacers are used between parts on a shaft to take up the extra space and prevent the parts from sliding on the shaft. If more than a few spacers are needed, it is typically better to use a shaft collar.

Spacers for the 15mm building system have a 5mm hex center, are made of Delrin, and come in 3 lengths (Table 5).

Table 5: Spacers

		
<p>1.5mm Spacers REV-41-1325</p>	<p>3mm Spacers REV-41-1324</p>	<p>15mm Spacer REV-41-1323</p>

Spacers and shaft collars are used for the same purpose: to constrain components on a shaft. This keeps shafts from falling out and also keeps motion components, such as gears and sprockets, aligned. For larger sections of exposed shaft, shaft collars are preferred because installing multiple spacers is less efficient and is more difficult to manage during robot building and maintenance. For shorter shaft lengths, spacers are generally more efficient (Figure 22).

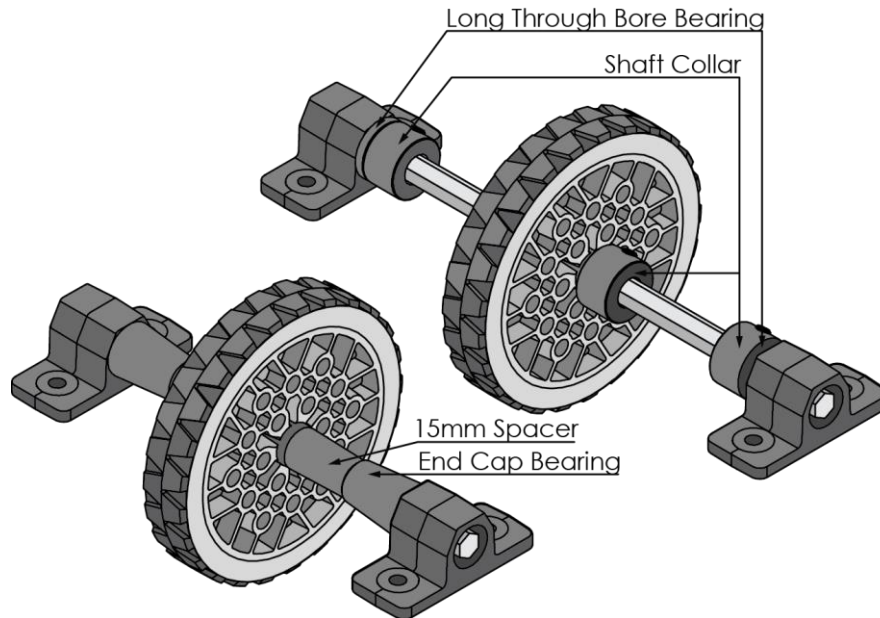
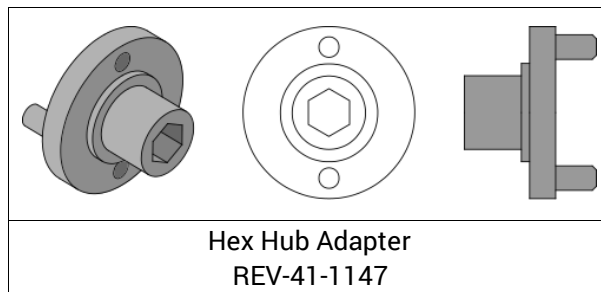

Figure 22: Shaft Collar and Spacer Side by Side

2.6 ADAPTERS

2.6.1 High Strength Hex Hub

The aluminum hex hub adapter is used to convert almost any of the Tetrax and AndyMark gears with the 4-hole mounting pattern to accept a 5mm hex drive shaft.



These aluminum hubs can be mounted to any of the REV robotics hex driven motion products to increase their maximum torque. When the hex hub adaptor is used on a REV product, such as the 60 tooth gear in Figure 23, the raised part of the hub should face away from the gear. There will be a small gap between the back of the hub and the body of the gear because of the built in spacer on the gear. Insert a shaft into both parts and then using M3x20mm and nylocs, evenly tighten the hub against the gear to ensure good alignment.

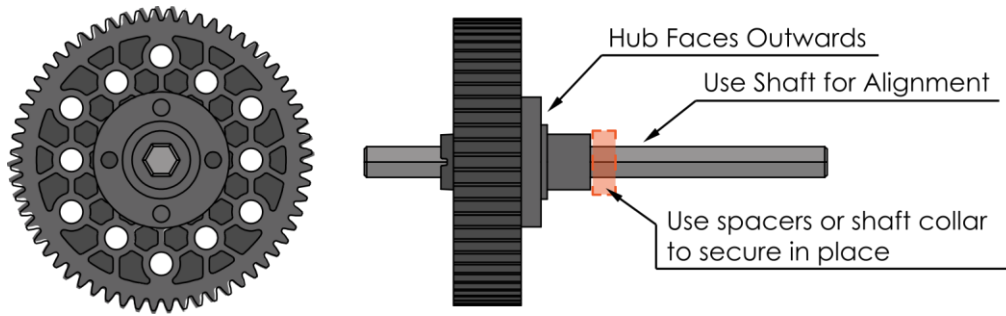

Figure 23: Hex Hub Adapter Mounted on a REV Gear for Added Strength

Hex hub adaptors allow teams to use the parts they already have with the reliability and convenience of a hex drive shaft. In Figure 24, a hex hub adaptor is mounted to an AndyMark Stealth Wheel using four M3x30mm bolts and nyloc nuts. The extended part of the hex hub adaptor is sized to pilot the hub into the wheel keeping it centered.

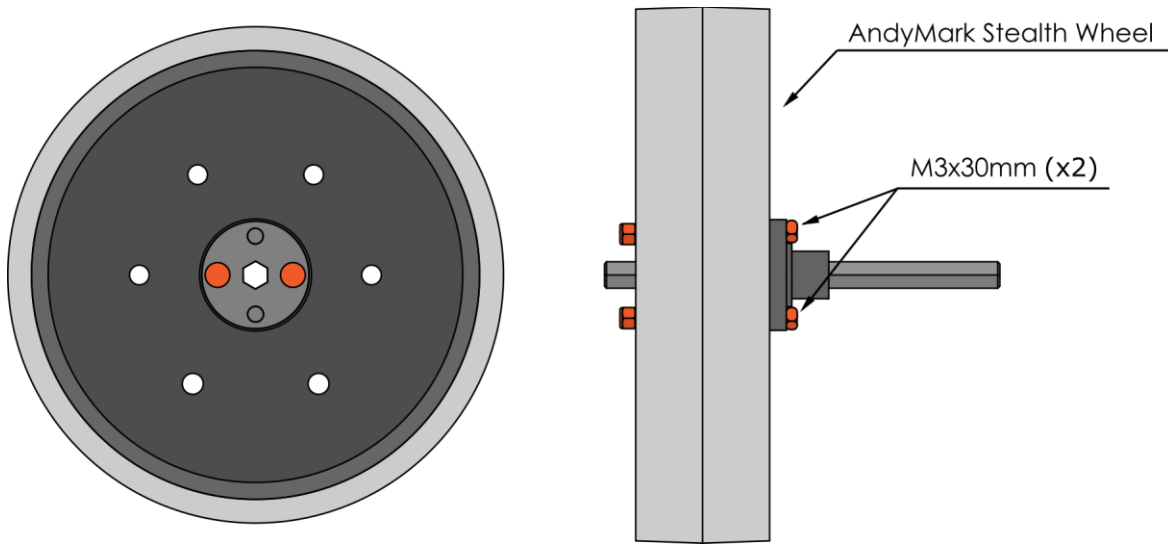
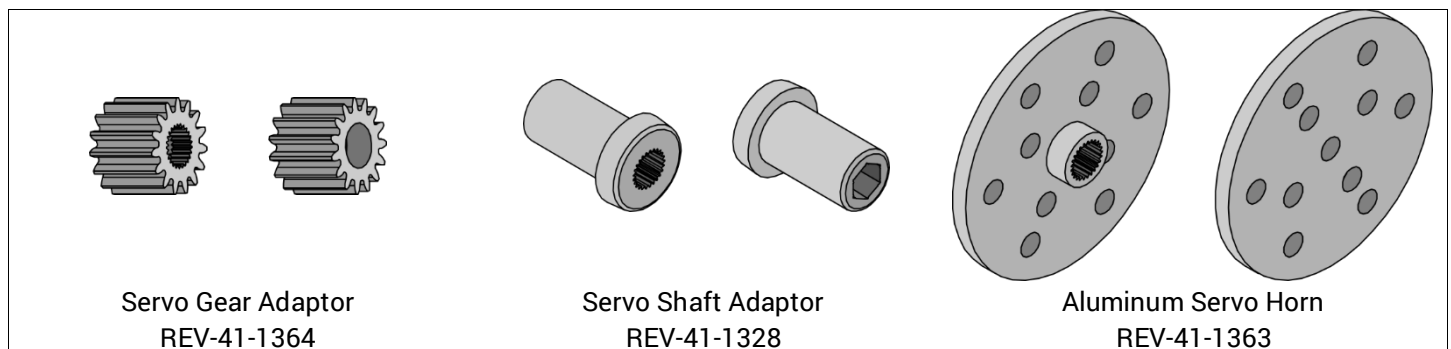

Figure 24: Hex Hub Adaptor used to convert an AndyMark Stealth Wheel to Hex Shaft

2.6.2 Servo Adapters

REV Robotics Servo Adapters fit 25T spline servos like the REV Robotics Smart Robot Servo (REV-41-1097). In addition to the variety pack of generic servo horns which come with the Smart Robot Servo, there are three other custom servo adapters which make using servos with the REV 15mm Extrusion building system very easy (Table 6).

Table 6: Servo Adapters



Servo Gear Adaptors convert a 25T servo into 15 tooth Delrin gear which is compatible with the other REV Robotics Gears.

Servo Shaft Adaptors convert a 25T spline servo output shaft into a female 5mm hex socket. This adapter can be used to use a servo to drive a hex shaft directly.

Aluminum Servo Horns have a tapped hole pattern that can be directly mounted to any of the “4-hole” pattern parts common in FTC, or can be mounted to any of the REV Robotics gears, wheels, or sprockets with a 6-hole pattern.

2.7 MOTION COMPONENTS

REV Robotics motion parts, including wheels, sprockets, and gears, all have a uniform thickness of 15mm (Figure 25). The purpose of this is to improve the iterative design experience. Changing from a gear reduction to a solution with chain and sprocket, or going direct drive, will not require any frame or spacer changes.

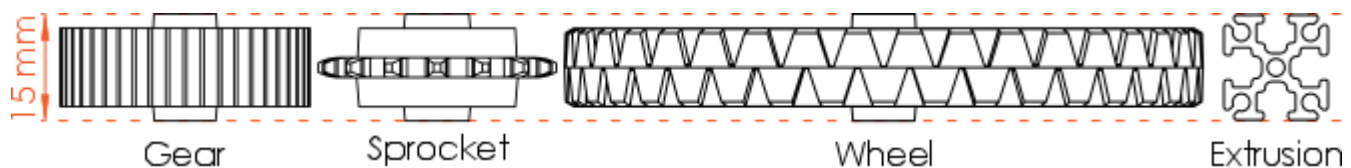

Figure 25: All Motion Parts Share Common 15mm Part Thickness

Product material selection is noted in Figure 19. Traction wheels are co-molded with a polyurethane tread for increased traction.

Table 7: Motion Component Materials

Component	Material
Sprockets	Acetal (Delrin/POM)
Gears	Acetal (Delrin/POM)
Pulley	Acetal (Delrin/POM)
Wheel Body	Nylon(PA66)
Traction Wheel Tread	Thermoplastic polyurethane (TUP)

All REV Robotics wheels, sprockets, and gears have a M3 bolt hole mounting pattern that is on an 8mm pitch as shown in Figure 26. This makes it easy to directly mount to REV Robotics brackets and extrusion. The 8mm pitch is also compatible with many other building systems.

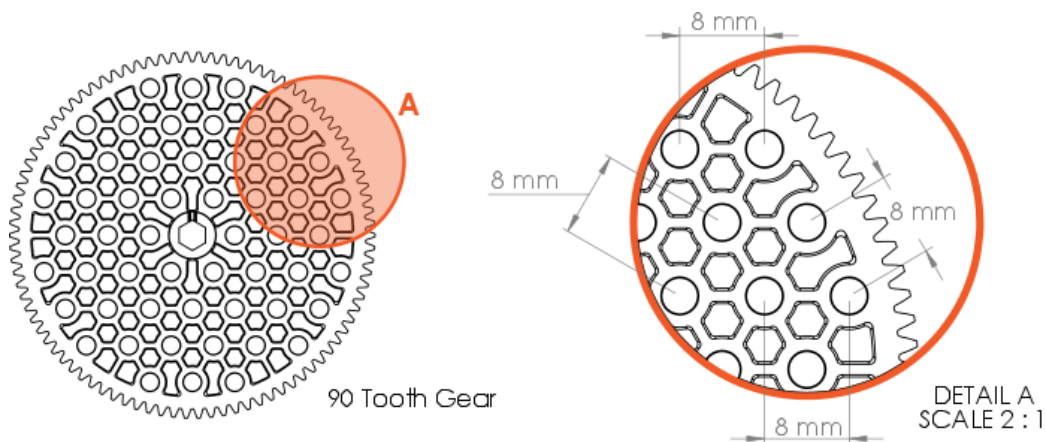

Figure 26: Motion Component Bolt Pattern Detail

Sometimes, it may be desirable to stack together multiples of the same gear or sprocket on a shaft. As a best practice, all components should have the alignment notch (Figure 27) oriented the same direction on the shaft. The alignment notch can be found on the raised hub on either side of the gear or sprocket.

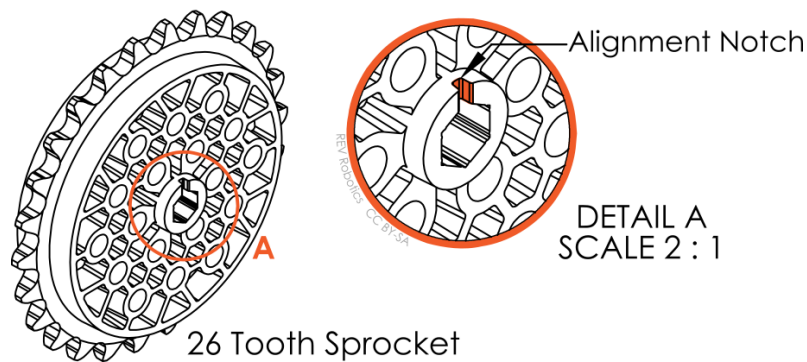

Figure 27: Shaft Alignment Notch Detail

In many cases the number of teeth on the gear or sprocket is not divisible by six, the number of sides on the hex shaft, and therefore the relative rotation between two of the same part will result in the teeth being out of alignment with each other. As Figure 28 shows, if the first sprocket was put on a shaft with the alignment notch facing upwards (noted by ①), there would be a valley at the top of the sprocket. If the second sprocket was added to the shaft, but rotated clockwise by 60 degrees (by the turn of one flat side), there would be most of a sprocket tooth at the top of that sprocket (noted by ②). It's possible to build a working system without aligning stacked parts, but it's not recommended.

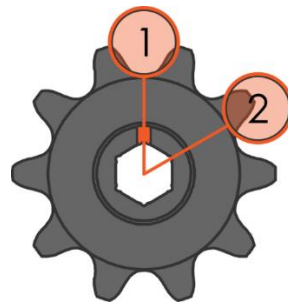

Figure 28: Shaft Alignment Example

2.8 WHEELS

The REV Robotics Building System has three different traction wheel sizes (Table 8) and two different Omni Wheel sizes (Table 9). Traction wheels are co-molded with a polyurethane tread for increased traction.

2.8.1 Omni Wheels

Omni wheels are a special kind of wheel that has smaller rollers round the circumference of the wheel. These rollers can passively roll perpendicularly to the direction the wheel is driven (Figure 29). This wheel makes it easier for a robot to turn and can also be used in conjunction with some advanced drivetrains to create more maneuverable robots.



Figure 29: Omni Wheel Rollers

A single omni wheel is the same thickness, 15mm, as all other motion components. In some applications, it might be desirable to stack two omni wheels, with one rotated by 60° from the other, as shown in Figure 30. By setting your wheels in this configuration you ensure that a roller is always in contact with the ground. This results in smoother operation and a more consistent ability to roll perpendicular to the normal rotation of the wheel.

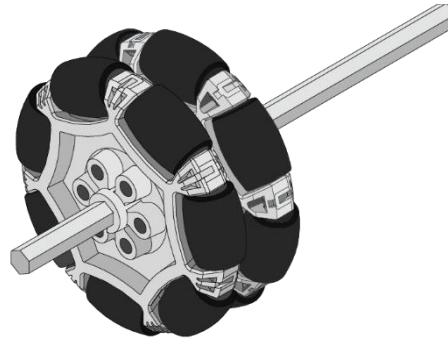

Figure 30: Double Stacked Omni Wheels

2.8.2 All Wheels

Table 8: Traction Wheels

<p>30mm Traction Wheel REV-41-1353</p>	<p>60mm Traction Wheel REV-41-1350</p>	<p>90mm Traction Wheel REV-41-1354</p>

Table 9: Omni Wheels

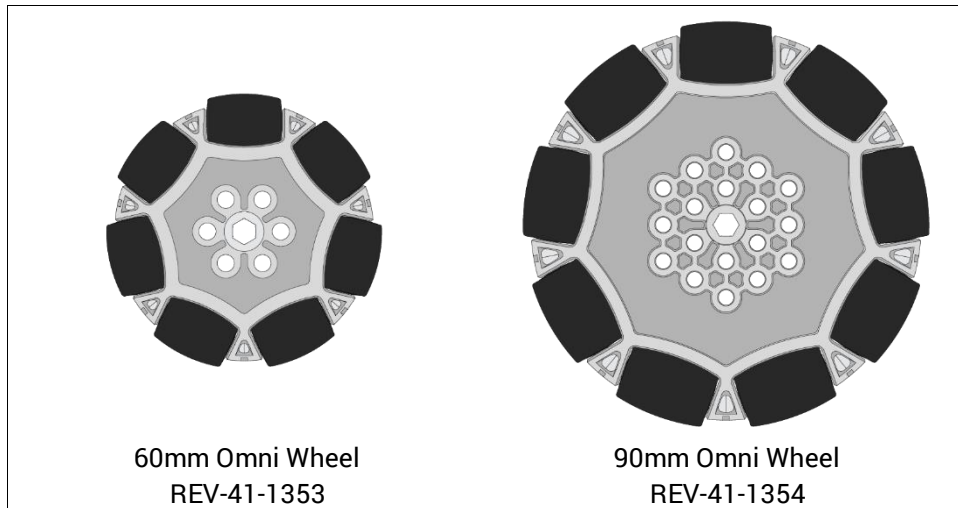

2.9 SPROCKETS AND CHAIN

REV Robotics sprockets are a #25 pitch and are made from molded acetal (Delrin/POM). Sprockets are designed to fit a 5mm hex shaft, which eliminates the need for special hubs and setscrews. The REV Robotics building system is designed around slotted extrusion which allows components attached to the extrusion to slide to any desired location for tension adjustment. There are six different sprocket sizes available with a maximum reduction of 5.4 (Table 10).

Sprockets are used with chain to transmit torque from one axle to another. By selecting sprockets larger or smaller relative to the input sprocket, we can either increase the output speed or increase the output torque as shown in Figure 31. However, the total power in the system is not effected.

When a larger sprocket drives a smaller one, for one rotation of the larger sprocket the smaller sprocket must complete more revolutions so the output will be faster than the input. If we reverse the situation and a smaller sprocket drives a larger output sprocket, then for one rotation of the input the output will complete less than one revolution resulting in a speed decrease from the input. The ratio of the sizes of the two sprockets is proportional to the speed and torque changes between them.

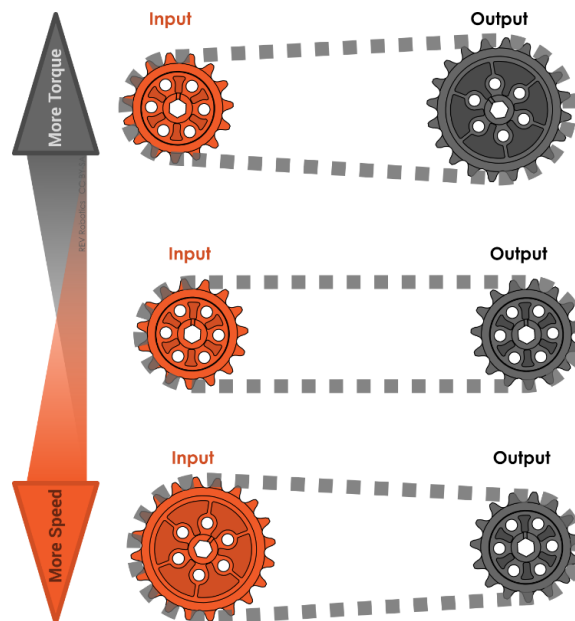

Figure 31: Using Sprockets to Increase Speed or Torque

From Figure 31 we know that the ratio in size from the input (driving) sprocket to the output (driven) sprocket determines if the output is faster (less torque) or has more torque (slower). To calculate exactly how the sprocket size ratio effects the relationship from input to output we can use the ratio of the number of teeth between the two sprockets.

Sprocket and chain is a very efficient way to transmit torque over long distances. Modest reductions can be accomplished using sprockets and chain, but gears typically provide a more space efficient solution for higher ratio reductions.

2.9.1 Chain Tension

In order for sprockets to work effectively, it is important that the center-to-center distance is correctly adjusted. The sprocket and chain in Figure 32 may work under very light load, but they will certainly not work and will skip under any significant loading. The sprockets in this example are too close together so chain is loose enough that it can skip on the sprocket teeth. The sprockets in Figure 33 are correctly spaced which will provide smooth, reliable operation.

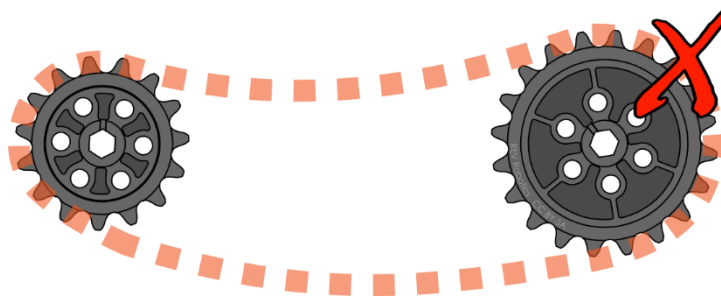

Figure 32: Incorrectly Spaced Sprockets (Chain too Loose)



Figure 33: Correctly Spaced Sprockets (Chain Correctly Tensioned)

To correctly space REV Robotics sprockets, use the following procedure:

1. Securely fix the axle of either the input or output sprocket. In the case of a gear train with multiple idlers or a compound reduction, consider which axle makes the most sense to fix such as the very first input gear or the very last gear.
2. Starting with the fixed axle, then identify all the driving and driven sprockets for any sprockets on that axle. One by one loosen these axles, slide them until the chain is tensioned and then retighten the axle mounts.
3. Continue the procedure from Step 2 for each fixed axle until all the chains are tight and all the axles have been retightened.

2.9.2 Anatomy of Chain

Roller chain is used to connect two sprockets together and transfer torque. Roller chain is made up of a series of inner and outer links connected together to form a flexible strand (Figure 34).

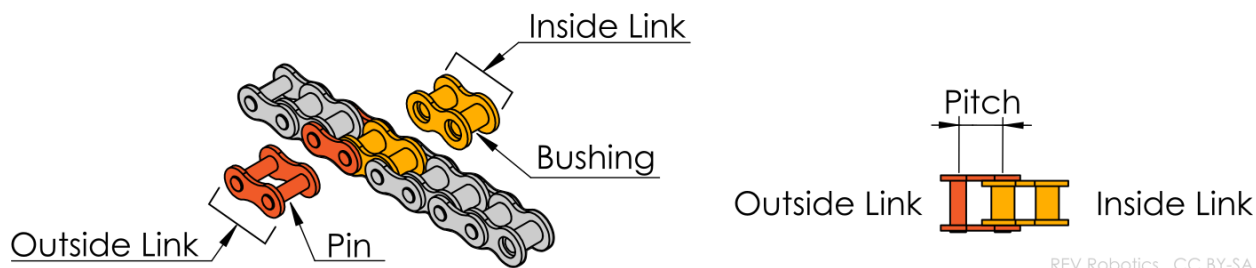

Figure 34: Basic Chain Nomenclature

Outside Links consist of two outside plates which are connected by two **pins** that are pressed into each plate. The **pins** in the outside link go through the inside of the hollow **bushings** when the inner and outer links are assembled. The **pins** can freely spin on the inside of the **bushings**.

Inside Link consist of two inside plates that are connected by two hollow **bushings** which are pressed into each plate. The teeth of the sprocket contact the surface of the **bushings** when the chain is wrapped around a sprocket.

Pitch is the distance between the centers of two adjacent **pins**. The REV Robotics building system uses #25 chain.

2.9.3 Custom Length Chain

In almost all applications, chain links are connected to form a loop. While chain can sometimes be purchased in specific length loops, it is more common to receive chain in bulk lengths and make custom loop lengths to fit the application. It is recommended to use a specialized tool, called a chain breaker, to cut chain into desired lengths in order to prevent accidental damage.

Chain breakers do not actually “break” or cut the chain, instead they are used to press out the pins holding a link together. After the pins have been removed the chain can be separated leaving inner links on both ends of the break. Refer to individual tool instructions for more specific and detailed chain break procedures.

2.9.4 Master Links

Roller chain is typically connected into a continuous loop. This can be done using a special tool to press the pins in and out of the desired outer link, or if the chain is already the correct length, an accessory called a master link, or quick-release link, (Figure 35) can be used to connect two ends of the chain.

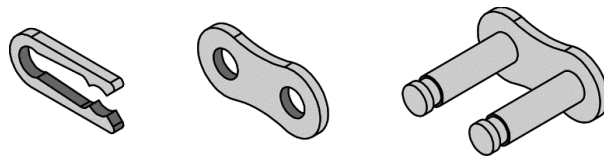

Figure 35: Master Link (Enlarged)

Master links allow for easy chain assembly/disassembly without any special chain tools. Master links can typically be reused many times, but will eventually become bent after repeated uses and should then be discarded. Master links replace an outside link in a section of chain, but before examining the master link connecting two sections of chain, Figure 36 depicts the basic operation for assembling a master link.

1. Place the loose outer plate onto the two pins pressed into the other outer plate.
2. Ensure the outer plate is inserted onto the pins far enough that the grooves on the pins are fully exposed past the outer plate.
3. Align the widest gap near the middle of the clip with one of the pins.
4. The gap in the clip should allow the clip to slip over the pin and sit flush against the outer plate and aligned with the groove in the pins.
5. Use pliers or another tool to slide the clip towards the other pin until the clip is securely engaged with the grooves on both pins.

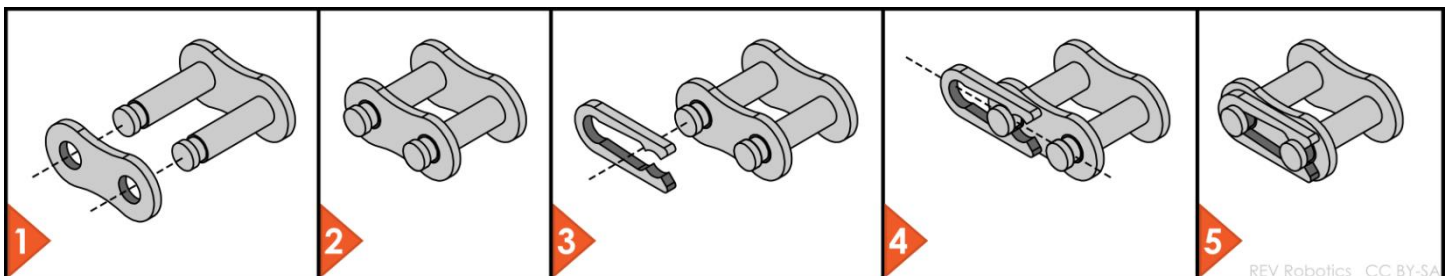

Figure 36: Master Link Detailed Assembly for Reference

Installing the clip as shown in Steps 4 and Step 5 of Figure 36 can be sometimes difficult.

There are a number of approaches that may work for these steps, but a common method is to use a pair of needle nose pliers to grip between the back of the clip and the nearest pin to slide the clip (Figure 37).

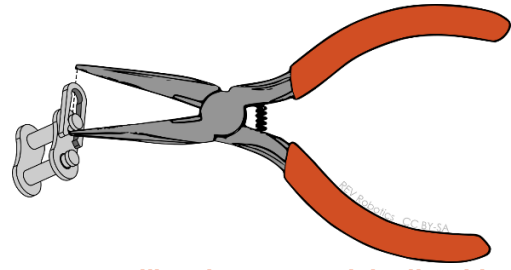

Figure 37: Installing the Master Link Clip with Pliers

Master links are used to connect two ends of a section of chain to create a loop of chain. In order to use a master link, the chain ends should both terminate with inside links (Figure 38). Slide the two pins from the master link into the rollers of the two terminating inside links. Follow the procedure from Figure 36 to complete the link installation.



Figure 38: Master Link Assembly on Chain

2.9.5 All Sprockets

Table 10: #25 Sprockets

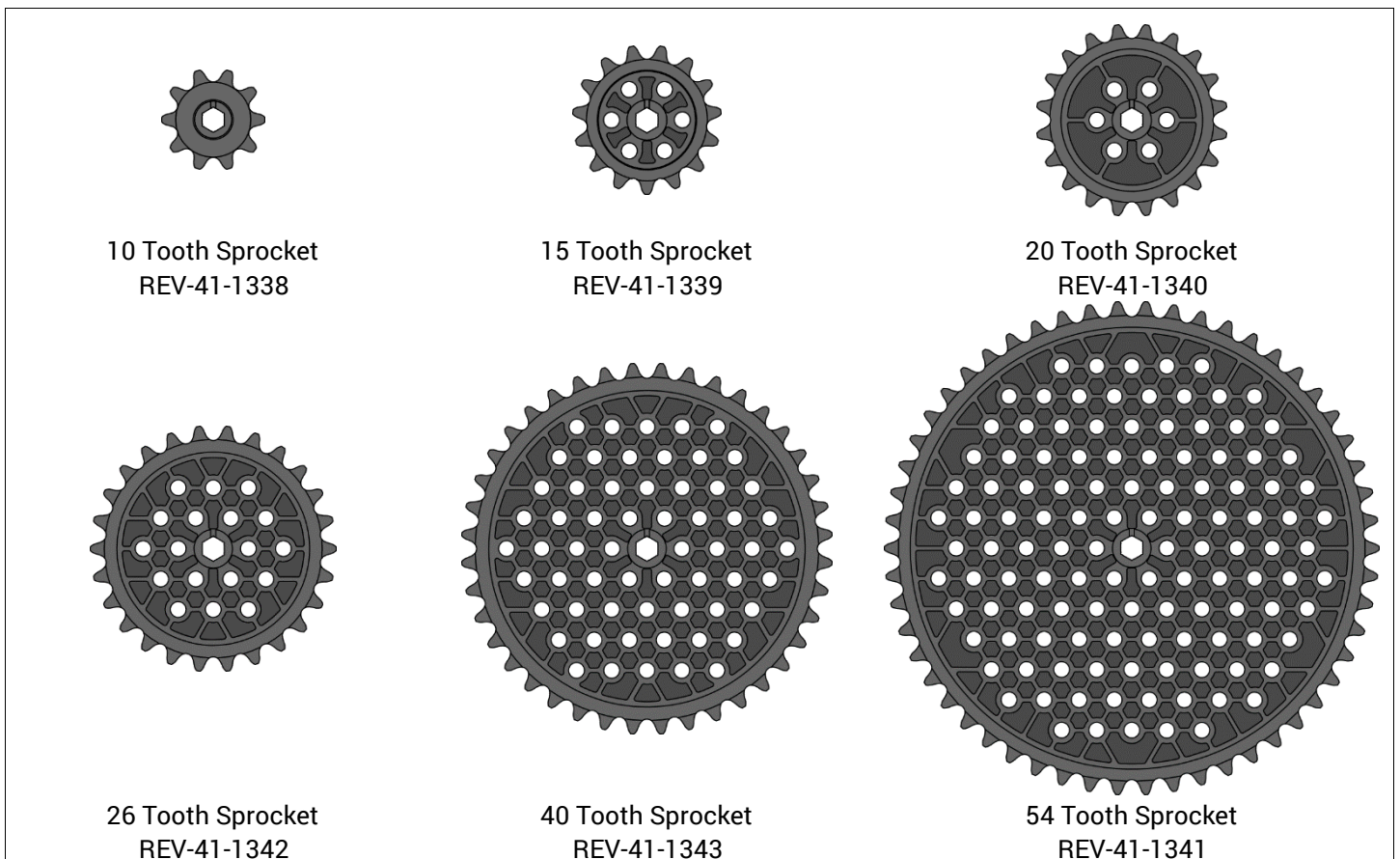

2.10 GEARS

Gears are rotating parts that have teeth and are meshed with other gears to transmit torque. Gears can be used to change the speed, torque (turning force), or direction of a motor's original output. For gears to be compatible with each other, the meshing teeth must have the same shape (size and pitch).

REV Robotics Gears have a 0.75 module, 20° pressure angle and are made from molded acetal (Delrin/POM). The webbed design with a wide face width and small tooth profile increases the gear strength without adding significant weight. REV Robotics Gears are designed to fit a 5mm hex shaft which eliminates the need for special hubs and setscrews. This system has seven different gear sizes with a maximum reduction of 8.3 (Table 11).

Meshing two or more gears together is known as a gear train. By selecting the gears in the gear train as larger or smaller relative to the input gear we can either increase the output speed, or increase the output torque as shown in Figure 39, but the total power is not affected.

When a larger gear drives a smaller one, for one rotation of the larger gear the small gear must complete more revolutions - so the output will be faster than the input. If the situation is reversed, and a smaller gear drives a larger output gear, then for one rotation of the input the output will complete less than one revolution - so the output will be slower than the input. The ratio of the sizes of the two gears is proportional to the speed and torque changes between them.

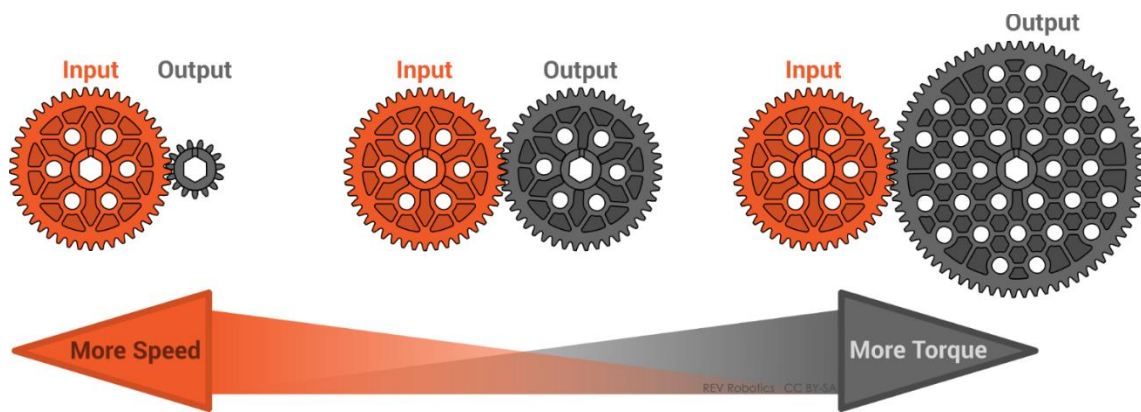

Figure 39: Using Gears to Increase Speed or Torque

2.10.1 Correct Gear Spacing

In order for gears to work effectively, and not become damaged, it's important that the center-to-center distance is correctly adjusted. The gears in *DETAIL A* of Figure 40 may work under very light load, but they will certainly not work and will skip under any significant loading. The gears in that example are too far apart and so the teeth of each gear barely contact each other. The gears in *DETAIL B* of Figure 40 are correctly spaced and will provide smooth and reliable operation.

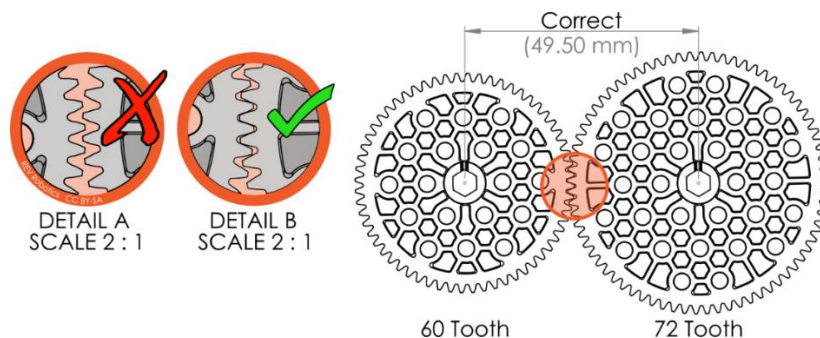

Figure 40: Gear Spacing Example

To correctly space REV Robotics Gears, use the following procedure:

1. Securely fix the axle of either the input or output gear. In the case of a gear train with multiple idlers or a compound reduction, consider which axle makes the most sense to fix, such as the very first input gear or the very last gear.
2. Starting with the fixed axle, identify all the driving and driven gears for any gears on that axle. One by one, loosen these axles and slide them until the teeth of both gears are fully engaged and parallel. Retighten the axle mounts.
3. Continue the procedure from Step 2 for each fixed axle until all the gears are tightly meshed and all the axles have been retightened.

2.10.2 All Gears

Table 11: Spur Gears

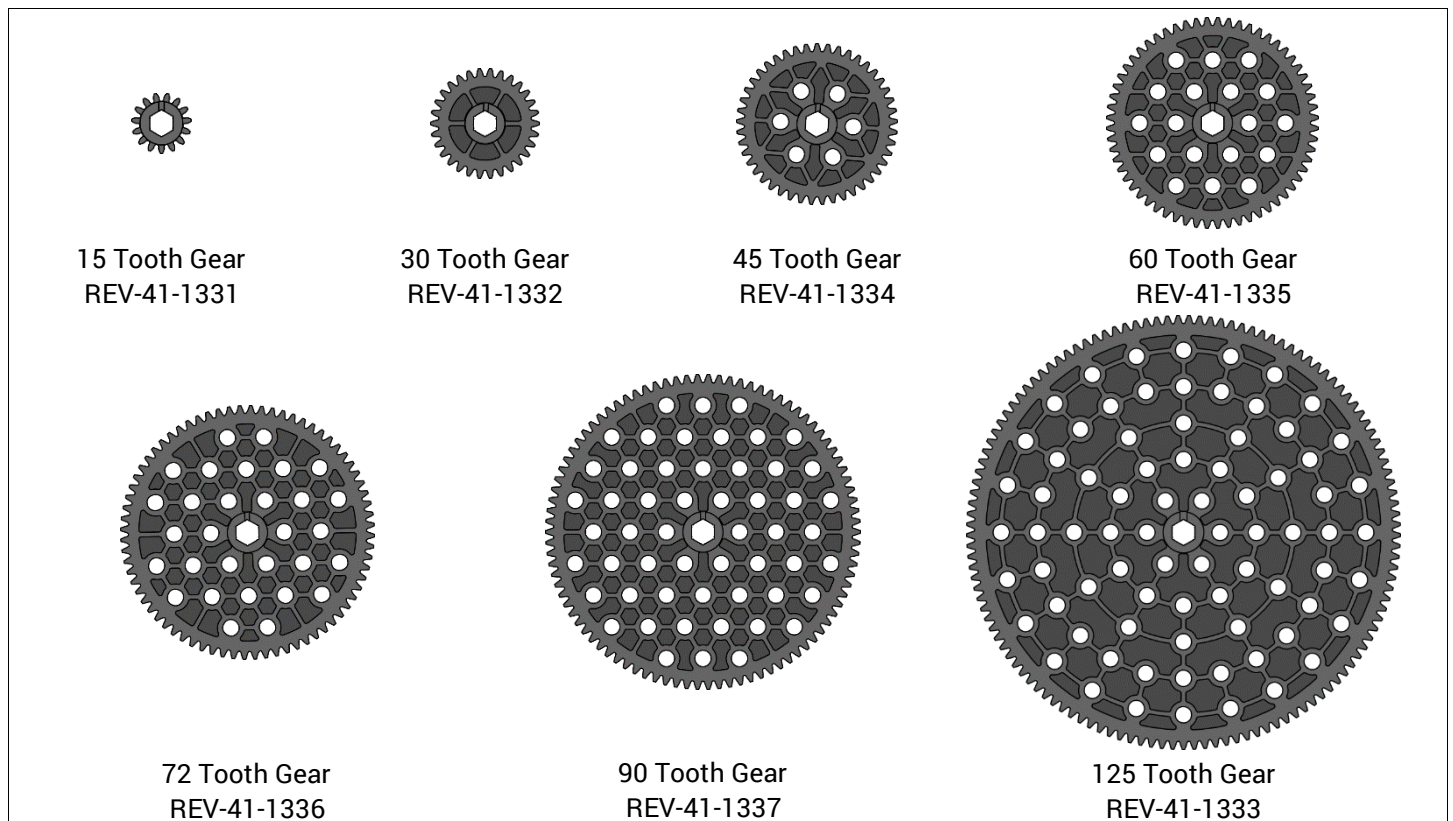

3 BASIC BUILDING GUIDE

3.1 ASSEMBLY TECHNIQUES

There are several different ways to assemble brackets and extrusion; these are explained in detail in this section. There is no right or wrong way, but different techniques may be needed if the end of the extrusion has become blocked during the assembly process.

3.1.1 BRACKET ASSEMBLY METHOD

Using pre-assembled brackets is the simplest way to install a bracket on extrusion. Brackets are preassembled with nuts and bolts before being slid into the extrusion slot and tightened (Figure 41).

1. Insert bolts into the desired bracket holes.
2. Put nuts onto the inserted bolts. Do not fully tighten these nuts, just a few turns will be enough. If using locknuts, finger tight is appropriate. There should be enough exposed thread on the bolt so that the bolt head can slide into the channel in the extrusion.
3. Slide the bolt heads into the extrusion slot. Note that the bolt heads will only fit if they are turned with flat sides parallel to the extrusion slot. Using a gentle shaking motion on the bracket while aligned with the slot can help align the bolt heads.
4. Slide the bracket to the desired location and tighten the nuts.

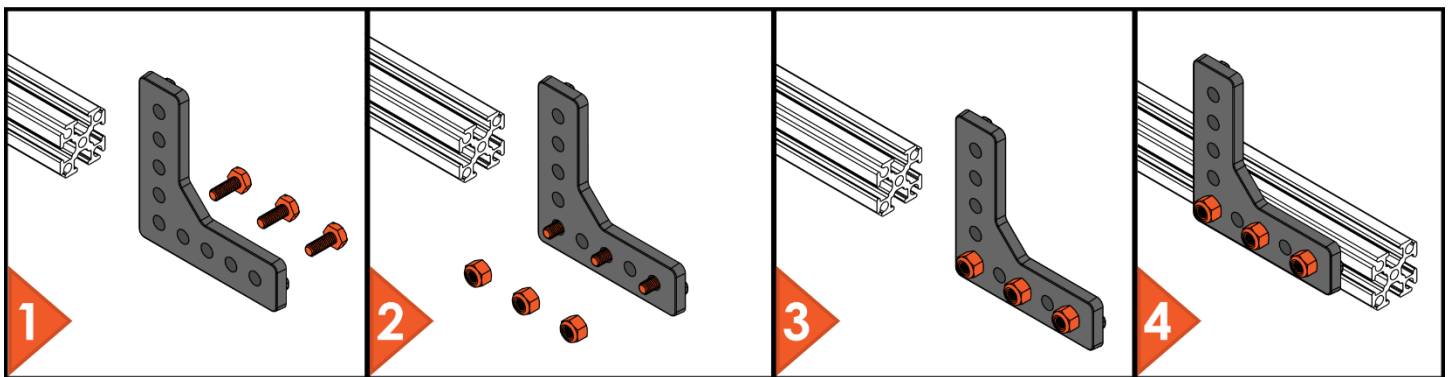

Figure 41: Preassembled Bracket Installation Method

3.1.2 BOLT-FIRST METHOD

The bolt-first method may be necessary when certain constraints prevent the bracket from sliding into its final position. Bolts are slid into the extrusion slot and then aligned with the bracket and nuts (Figure 42).

1. Slide the required bolts into the extrusion channel.
2. Slide the bolts so that they are approximately spaced to fit into the bracket.
3. Place the bracket on the protruding bolts.
4. Add nuts to the exposed bolts, slide the bracket into position and tighten.

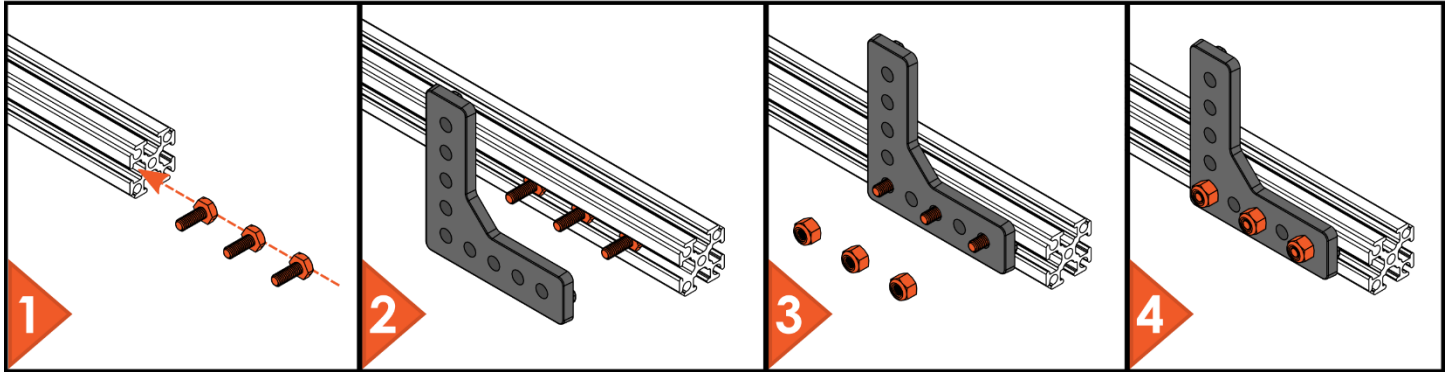

Figure 42: Bolt-first Assembly Method

3.1.3 ACCESS-HOLE METHOD

The access-hole method is necessary when the ends of the extrusion profile are blocked preventing bolts from entering the slots. Drill a 6.5mm (1/4") hole centered on the slot in a convenient location away from the final bracket position (Figure 43).

1. Drill a 6.5mm (5/16") hole centered on the extrusion slot away from the final bracket location. Drop the bolt heads into the hole and then slide them into the slot one by one.
2. Align the bolts so their spacing approximately matches with the bracket hole spacing.
3. Place the bracket on to the protruding bolts.
4. Start the nuts on all of the protruding bolts. Slide the bracket to the desired final location and tighten the nuts.

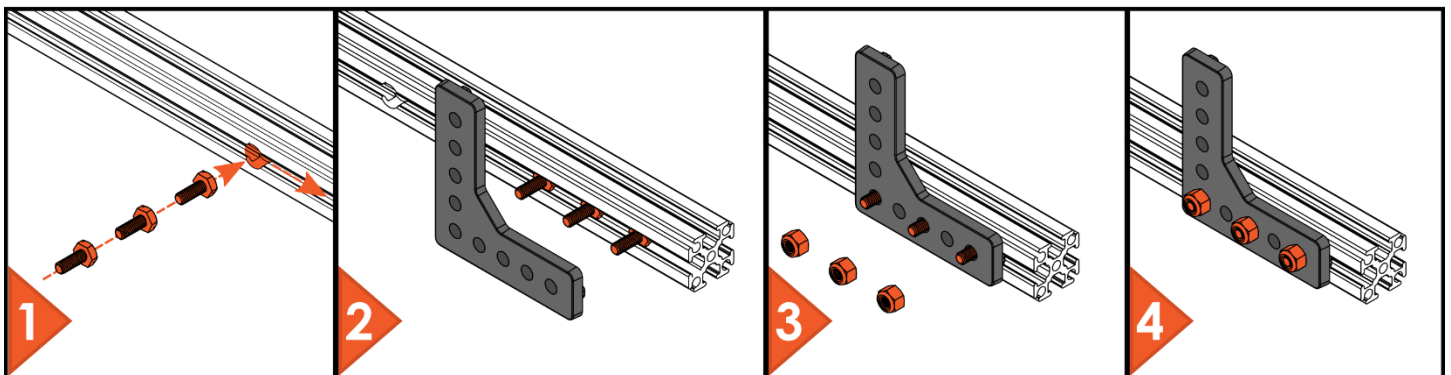

Figure 43: Access-hole Assembly Method

3.1.4 DROP-IN BOLT METHOD

Drop-in bolts are specialty bolts with a modified head profile which allows them to be inserted into the extrusion channel without needing to drill an access hole (Figure 44).

1. Place drop in bolts in the extrusion slot.
2. Align the bolts so their spacing approximately matches with the bracket hole spacing.
3. Place the bracket on to the protruding bolts.
4. Start the nuts on all of the protruding bolts. Slide the bracket to the desired final location and tighten the nuts.

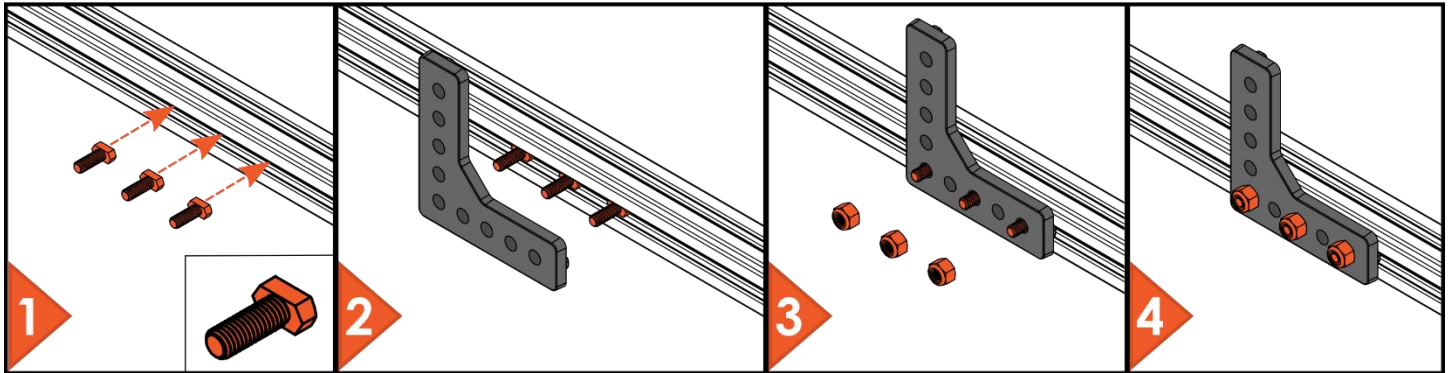

Figure 44: Drop-in Bolt Assembly Method

3.1.5 END-TAPPED EXTRUSION METHOD

The end-tapped extrusion assembly method is good for quick simple structures to verify spacing of a design. This is not a primary building method and once the correct spacing has been established, a bracket should be added to reinforce the joint.

1. Thread the M3 bolt into the center hole on the end of the extrusion. Using a standard driver, the bolt should self-tap into the end of the extrusion. An actual M3 tapping tool can also be used if desired.
2. Tighten the bolt until it feels securely threaded into the hole. Leave enough thread exposed that the head can be slid into the channel of another piece of extrusion.
3. Slide the extrusion with the bolt in it to the desired location and then turn the extrusion to tighten the bolt.
4. This joint is sufficient for quick, light duty testing, but brackets should be added when the design is finalized.

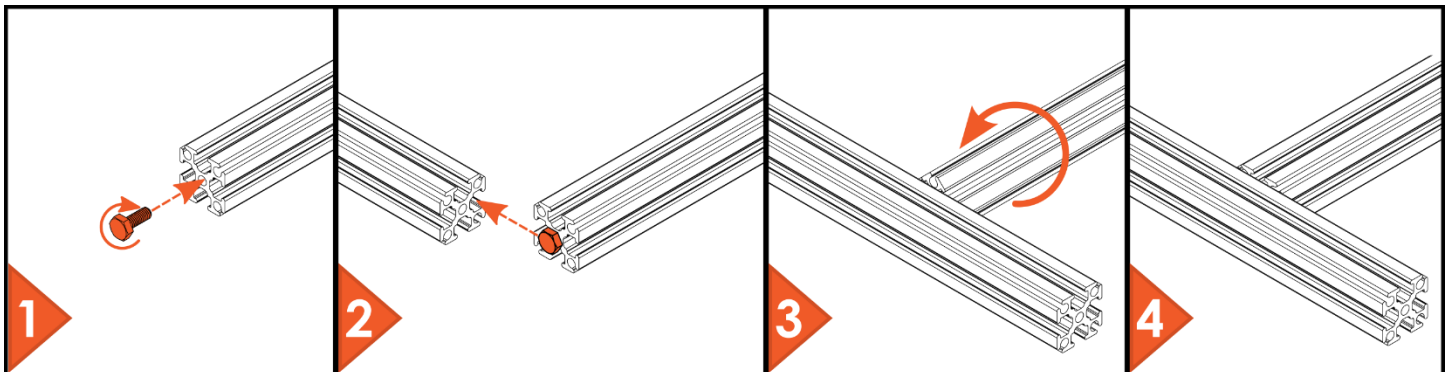

Figure 45: Extrusion to Extrusion Quick Joint

3.2 DRIVE TRAIN GUIDE

3.2.1 DROP CENTER 6-WHEEL DRIVE

When designing a 6-wheel drive robot, it is typically desirable to drop the center wheel by a small amount in order to improve the turning ability of the robot. There are two straight forward ways to do this using the 15mm REV Extrusion Building System.

In Figure 46, the center wheel is dropped by about $1/8^{\text{th}}$ of an inch using the [Indexable Motion Bracket](#) with motion brackets on the outside wheels. The Indexable motion bracket is easily adjustable in 1mm increments, so the ideal center drop for a robot design can be determined quickly through testing.

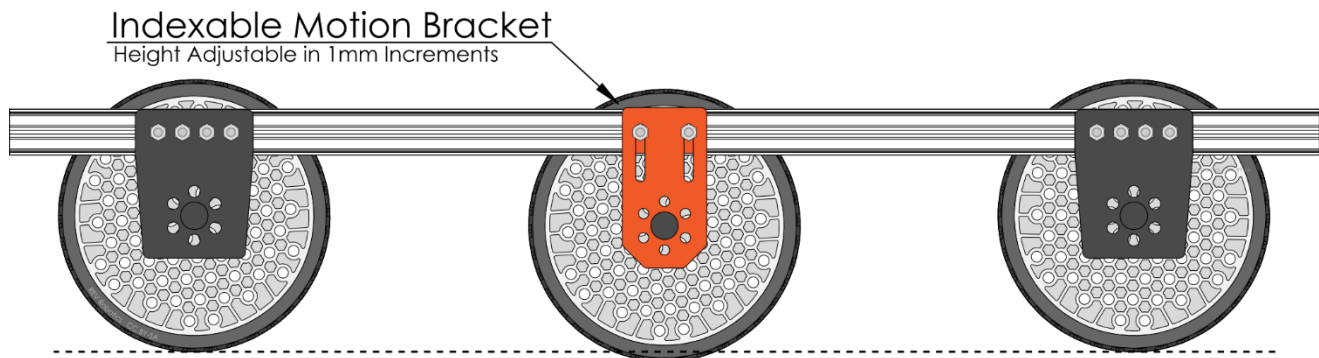

Figure 46: Drop Center Wheel Using an Indexable Bracket

Figure 47 shows an alternate way to create a dropped center wheel using all pillow blocks. The center pillow block has had the alignment ribs (small bumps on the bottom) sanded down, and then washers or a custom fit piece of plastic sheet inserted underneath. The bolts hold the pillow block and the washers to the extrusion. The thickness or number of washers can be changed to adjust the amount of center drop.

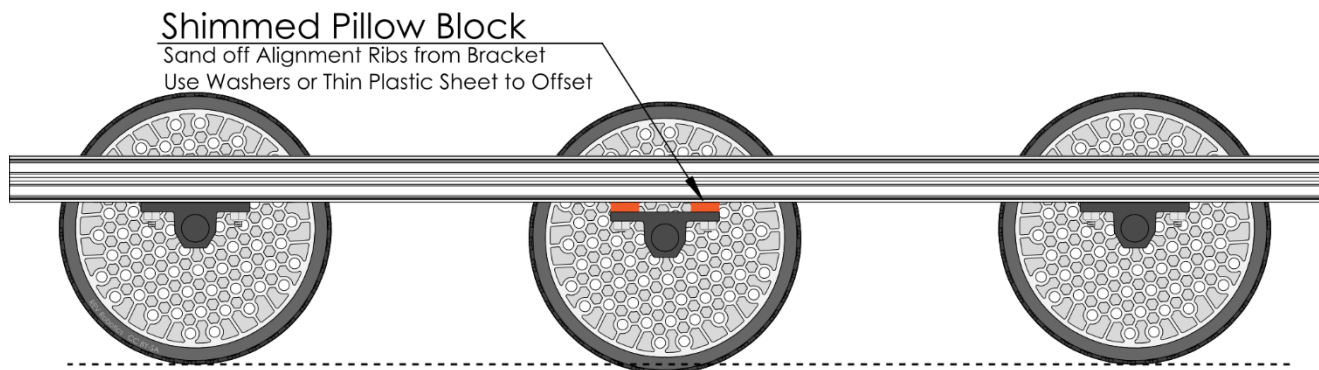

Figure 47: Drop Center Using a Shimmed Pillow Block

3.2.2 Geared Drive Train

Idler gears are a good way to transmit power across distances in your robot. An idler gear is any intermediate gear which does not drive an output shaft. Idler gears are used to transmit torque over longer distances than would be practical by using just a single pair of gears.

A common example of this is an all gear drivetrain (Figure 48). In this example, the gears on the end are linked to the drive wheels with one of the center gears being driven by a motor (not shown). The orange arrows indicate the relative rotation of each of the gears showing that the two wheels are mechanically linked and will always rotate in the same direction. Because idler gears reverse the direction of rotation, it is important to pay attention to the number of gears in

the drivetrain. In Figure 49, because there is an even number of gears in the drivetrain the wheels will always spin in opposite directions, which would get that robot nowhere fast.

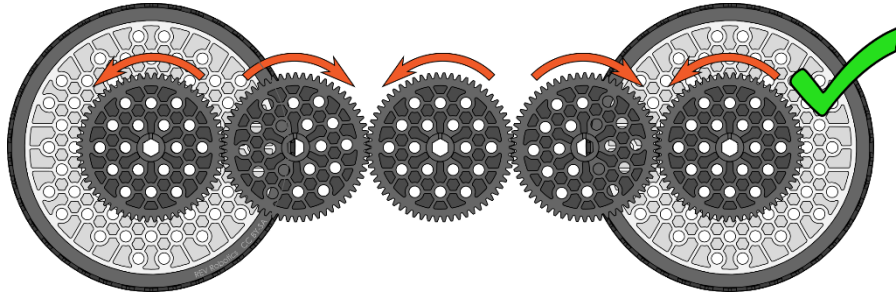

Figure 48: Correct All Gear Drivetrain

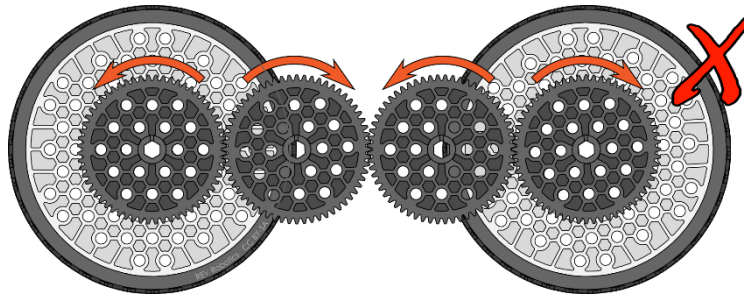

Figure 49: Incorrect All Gear Drivetrain

3.2.3 Sprocket and Chain Drive Train

Sprocket and chain is an efficient way to transmit torque long distances in a robot. A common example of this is a sprocket and chain drivetrain (Figure 50). In this example, the sprockets on the ends are linked to the drive wheels and the center sprocket is driven by a motor (not shown). Because the driving and driven sprockets are all inside the chain, they all have the same rotation direction. The smaller sprockets on the outside of the chain loop are used to increase the amount of chain wrap on the driving sprocket.

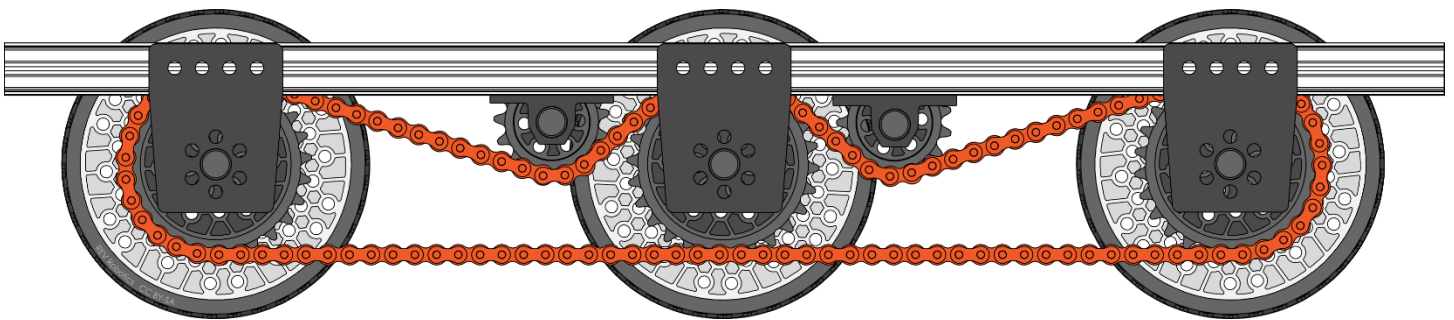

Figure 50: Example Sprocket and Chain Drive Train

All sprockets on the same side of a chain have the same rotation. In Figure 51, the driving and driven sprocket are inside the chain and are rotating counter clockwise while the idler sprocket is outside of the chain loop and is rotating clockwise.

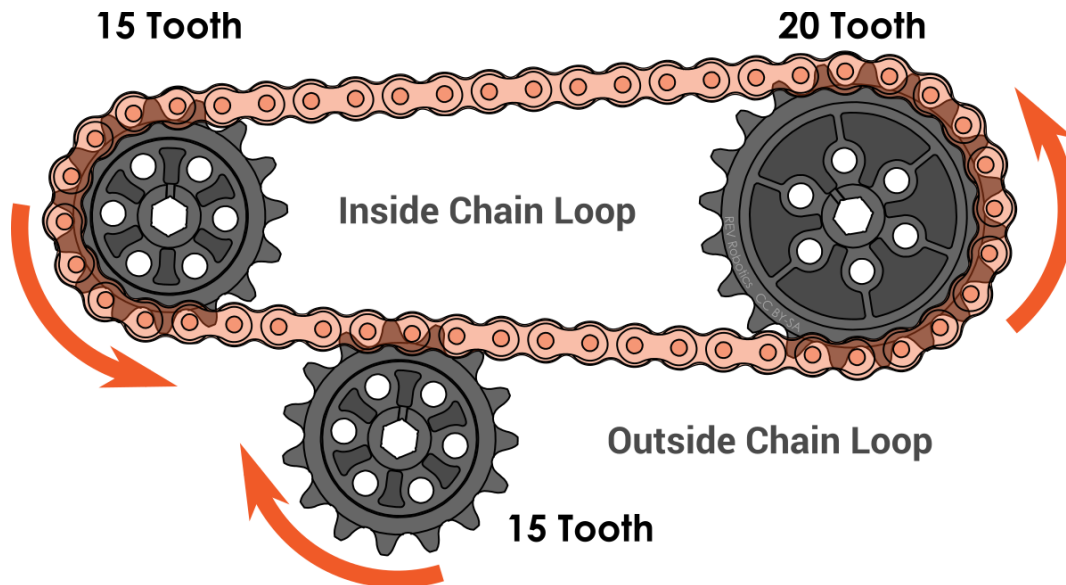

Figure 51: Single Stage Reduction (15:20) with Idler

Idlers can be used to tension chain or increase the amount of chain wrap around a sprocket. From Figure 52, all power transmission sprockets should have chain wrapped approximately 180° around the circumference of the sprocket. This amount of wrap is necessary so that there are sufficient teeth engaged with the chain to transmit the torque. Too little wrap ($<120^\circ$) and the chain will skip under heavy load, while excessive wrap ($>200^\circ$) can decrease system efficiency. In Figure 52 the sprocket outside of the chain is noted with a warning because it has a chain wrap of $<90^\circ$. If this sprocket is an idler, then it is unpowered and minimal chain wrap is acceptable, however if this sprocket will be driving a shaft then this amount of wrap would be insufficient.

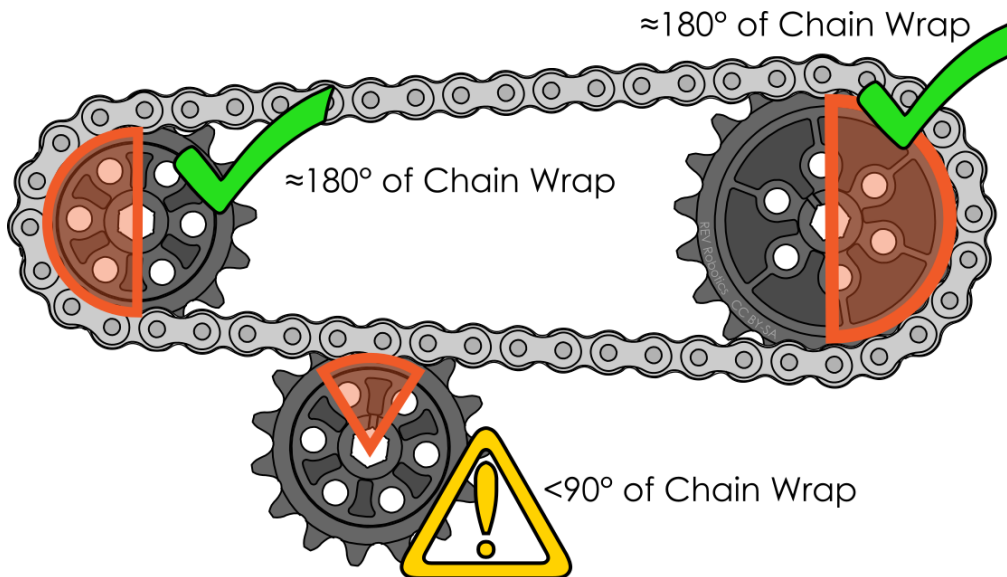

Figure 52: Chain Wrap Illustration

3.3 ARM GUIDE

3.3.1 SIMPLE ARMS

Two methods to create a simple arm are shown in the figures below. Figure 53 uses a Hex Pillow Block bolted to a piece of extrusion and the hex shaft can be rotated (not shown) to turn the light duty arm. In Figure 54 gears are bolted to the extrusion for a heavier duty arm. In this example another shaft with gears can be placed parallel to the arm pivot to drive the larger gears.

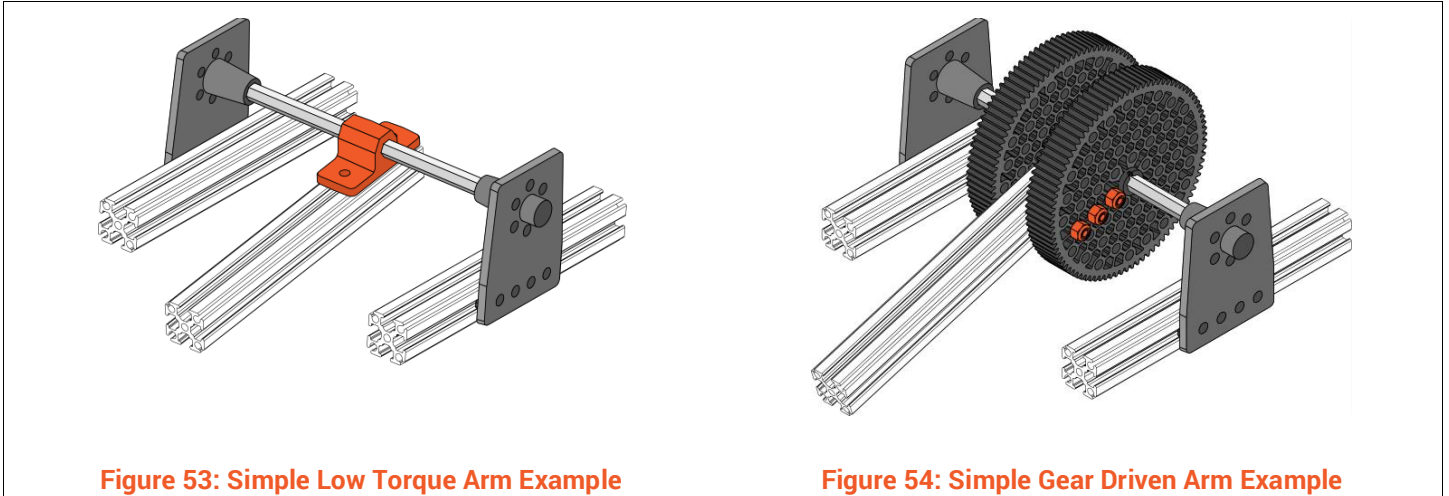

Figure 53: Simple Low Torque Arm Example

Figure 54: Simple Gear Driven Arm Example

3.4 COMPATABILITY GUIDE

Increase the reliability of any robot system by switching from set screws to hex shaft. Set screws can become loose and damage your shafts over time but using a hex shaft to transmit torque doesn't require any set screws or keys, it just simply works.

Converting part of an existing design, or using already purchased parts, with hex is easy. The simplest option is to change to the HD Hex Motor and directly drive either a REV Robotics Traction wheel, or use a HEX Hub with existing 4-hole pattern wheel. Use a shaft collar to secure the wheel from sliding off the shaft. (Figure 55)

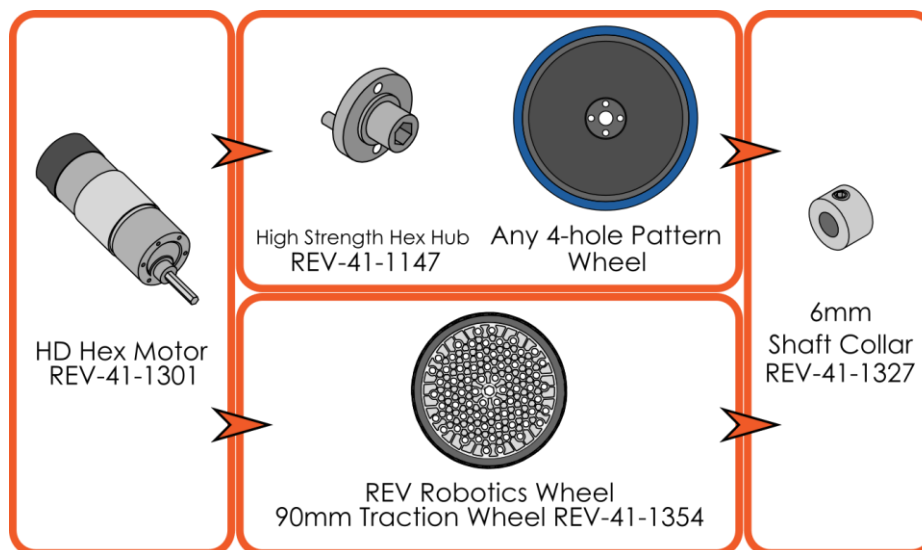

Figure 55: Direct Driven Wheel Using Hex

For a system with more shafts, the easiest way to couple between Hex and non-hex shafts is to use #25 pitch chain because it's common to all systems. In designs with multiple chain stages it's possible to change any number of the shafts over to hex. The more shafts converted, the less risk of a set-screw skipping and causing a failure. Starting from the motor and then changing subsequent shafts will provide the most benefit, but any shaft that's converted to hex will reduce a point of failure.

Figure 56 the HD Hex Motor is used with either a REV Robotics Sprocket or a Hex Hub with any 4-hole pattern sprocket. Connected by chain to the next shaft which can either be another REV Robotics based hex shaft or can connect to any existing #25 pitch chain solution a team already owns.

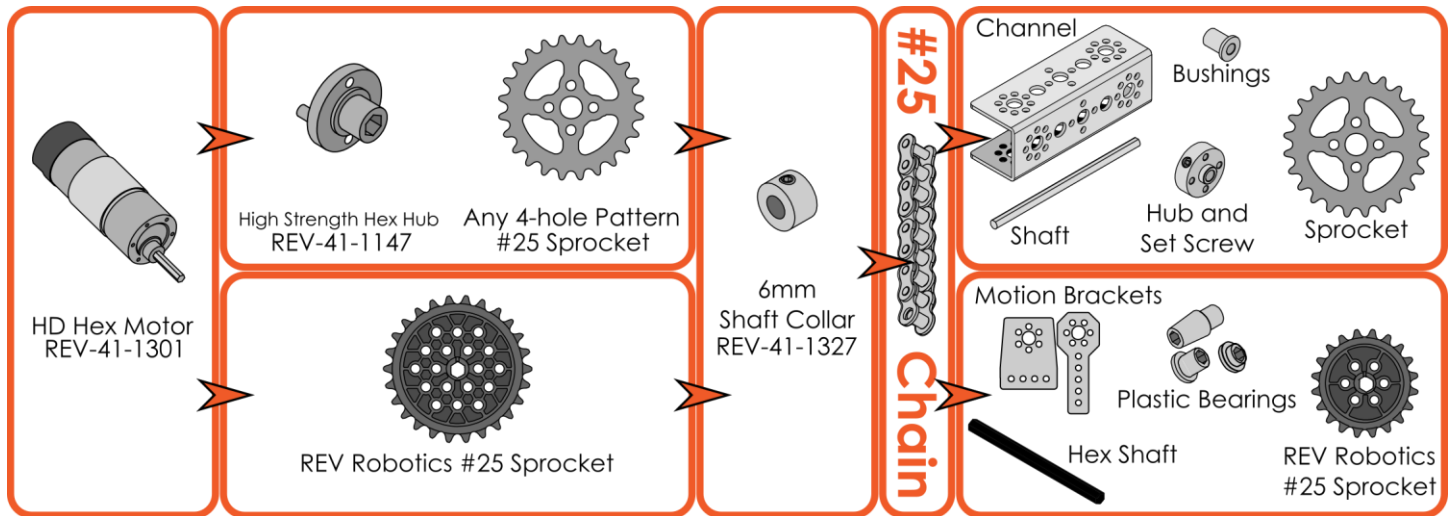

Figure 56: Sprocket and Chain Drive with Hex

Hex hub adaptors are specifically designed to help teams use the parts they already have with the reliability and convenience of a hex drive shaft. In Figure 57: Hex Hub Adaptor used to convert an AndyMark Stealth Wheel to Hex Shaft. Figure 24, a hex hub adaptor is mounted to an AndyMark Stealth Wheel using four M3x30mm bolts and nyloc nuts. The extended part of the hex hub adapter is sized to pilot the hub into the wheel keeping it centered.

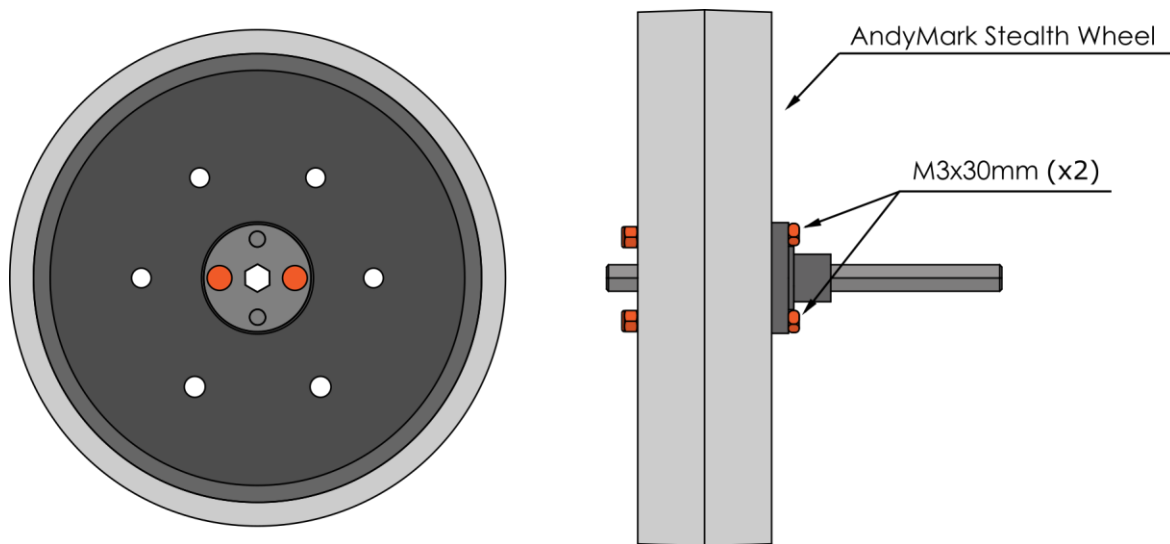

Figure 57: Hex Hub Adaptor used to convert an AndyMark Stealth Wheel to Hex Shaft

The REV Robotics Plastic Brackets have mounting holes on an 8mm spacing which is compatible with other building systems commonly used by FTC teams. When mounting a REV Robotics Plastic Bracket to flat channels, turn the bracket so that the alignment ribs on the bracket face out from the channel as shown in Figure 58.

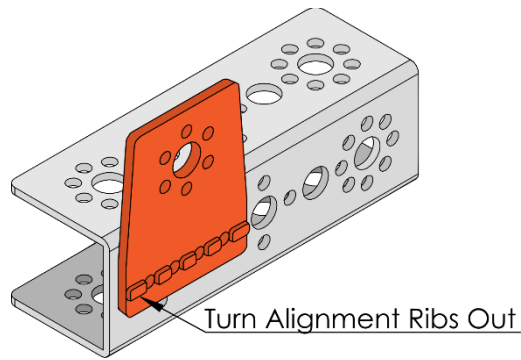

Figure 58: REV Robotics Plastic Bracket on Tetrax Channel with Alignment Ribs Facing Out

Tetrax channels also use an 8mm hole spacing so almost all REV Robotics brackets can mount directly to the channel. In Figure 59, there are several examples of how to mount motion brackets and a structural bracket to the Tetrax Channel. The motion brackets accept a REV Robotics 9mm bearing so they can be used to add hex shaft to a Tetrax robot.

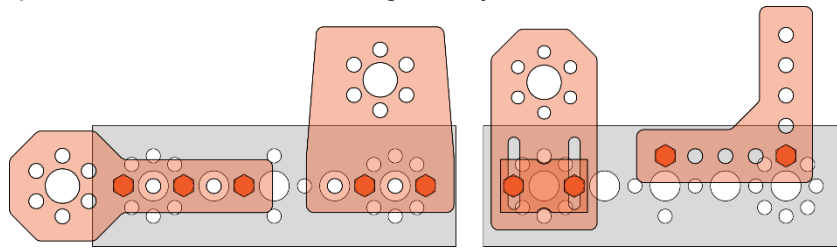

Figure 59: Mounting REV Robotics Brackets to Tetrax Channel

The 90 degree bracket in Figure 59 above is one way to mount extrusion to Tetrax channel. A stronger method would be to miter the end of the extrusion as needed and then bolt it directly to the Tetrax channel as shown in Figure 60. Install M3 hex cap bolts and nylocs in the Tetrax channel with the heads on the side the extrusion will be installed on. Slide the extrusion into place with the bolt heads in the extrusion channel and tighten. This method will also work with Actobotics channel.

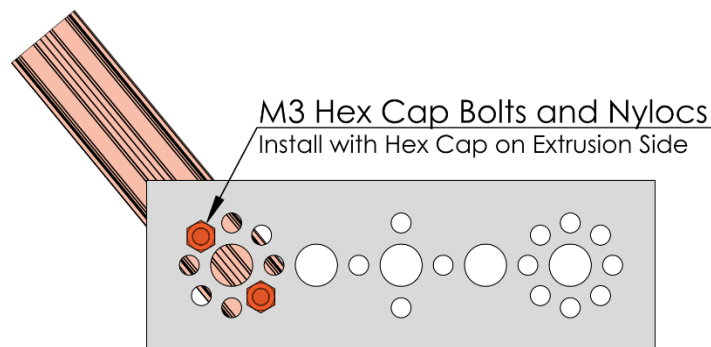

Figure 60: Mounting 15mm Extrusion to Tetrax Channel

To use the REV Robotics Plastic bearings directly in place of the Tetrax bushing, it's recommended to drill out one of the Tetrax pattern 8mm holes to 3/8" (larger than 9mm) and then install a motion bracket over the clearance hole (Figure 61). Depending on which 8mm hole in the Tetrax pattern is used it's possible to match drill and add more fasteners to secure the bracket. It is not recommended to use a plastic bearing directly in the metal channel because of durability concerns. The Delrin bearings are designed specifically to run in the nylon brackets for low friction and long wear.

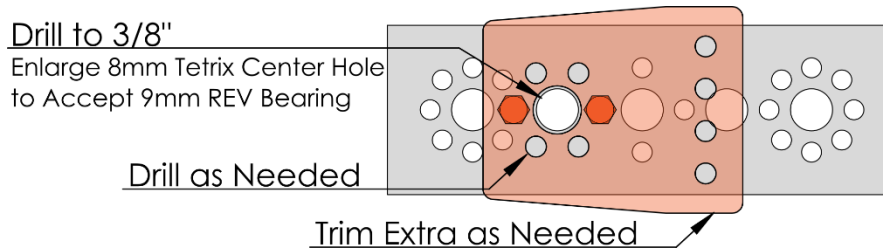

Figure 61: Using REV Robotics Bearings with the Tetrax Hole Pattern

Actobotics' channel is not on an 8mm pitch, but there are still several opportunities to mount REV robotics brackets to the channel. In Figure 62 a Motion Bracket is mounted to the Actobotics channel opening up the use of hex shafts for the Actobotics system with the addition of Motion Brackets and Plastic Bearings. When installing Plastic REV Robotics Brackets on metal channel, ensure the raised alignment ribs face outward so the back of the bracket sits flat in contact with the channel for strength.

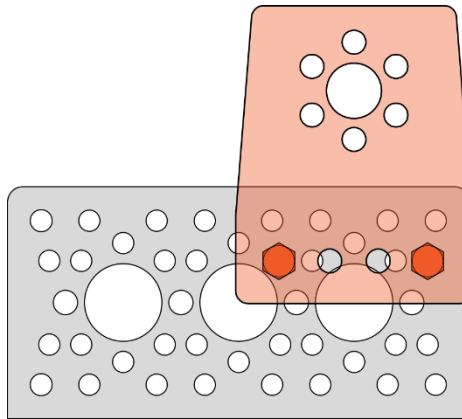
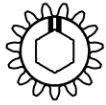

Figure 62: Motion Bracket Mounted to Actobotics Channel

4 ALL COMPONENTS (1:1 Scale)

This section has 1:1 scale drawings for the REV Robotics 15mm Extrusion Building system components. Use this list as a reference for part numbers, or print the pages out at full scale and use them to help identify unknown parts.

4.1 GEARS (1:1)



REV-41-1331
15 Tooth Gear

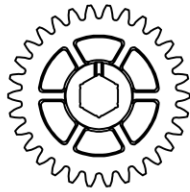

REV-41-1332
30 Tooth Gear

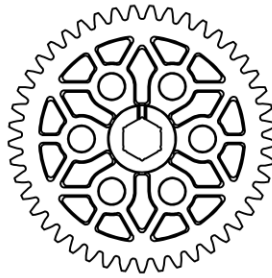

REV-41-1334
45 Tooth Gear

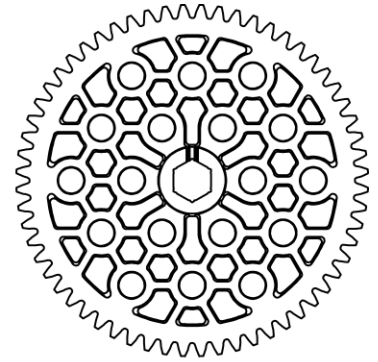

REV-41-1335
60 Tooth Gear

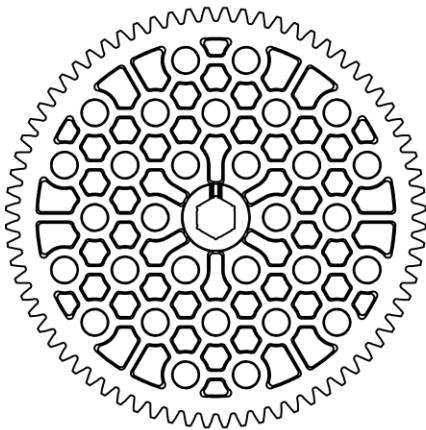

REV-41-1336
72 Tooth Gear

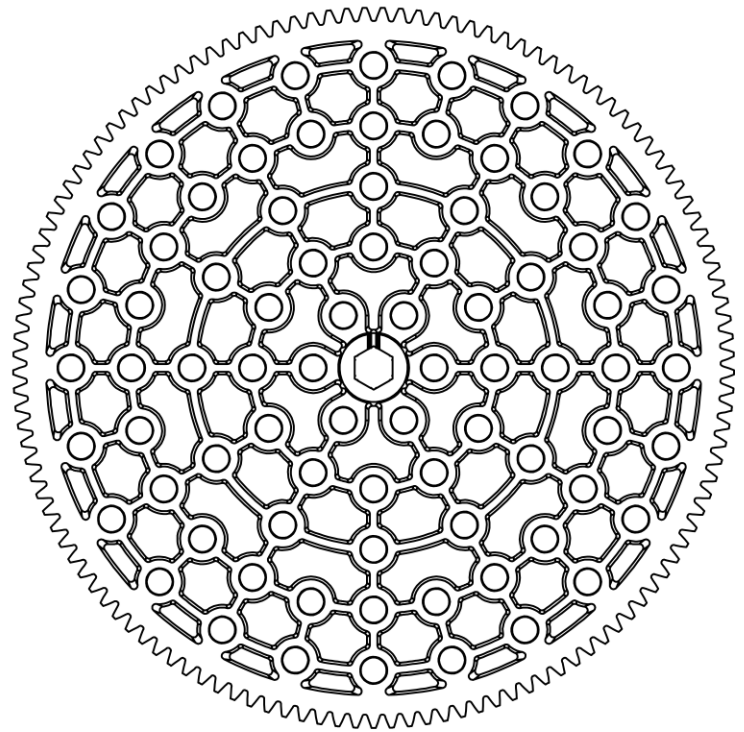

REV-41-1333
125 Tooth Gear

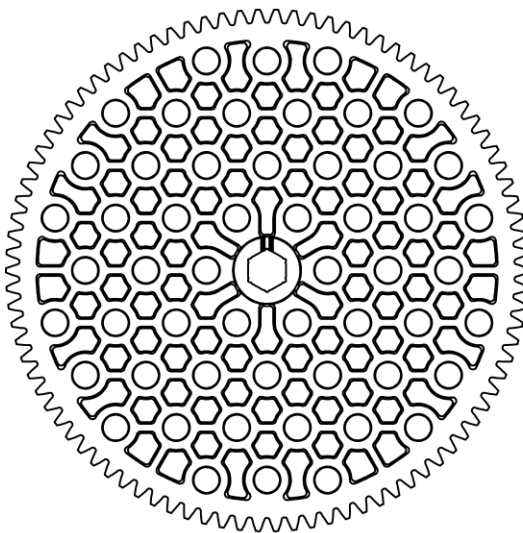

REV-41-1337
90 Tooth Gear

4.2 SPROCKETS (1:1)

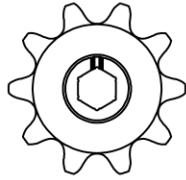

REV-41-1338
10 Tooth Sprocket

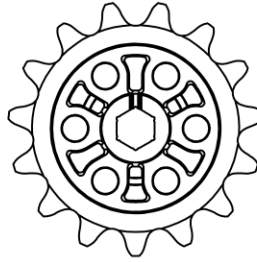

REV-41-1339
15 Tooth Sprocket

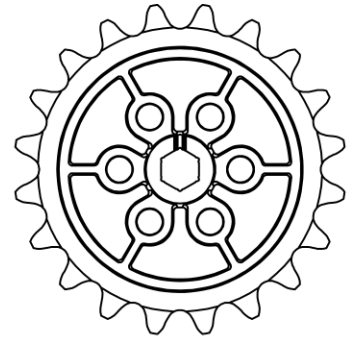

REV-41-1340
20 Tooth Sprocket

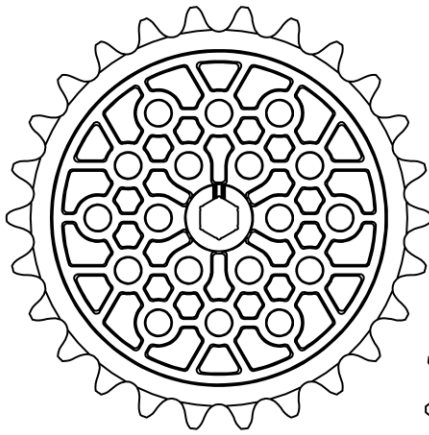

REV-41-1342
26 Tooth Sprocket

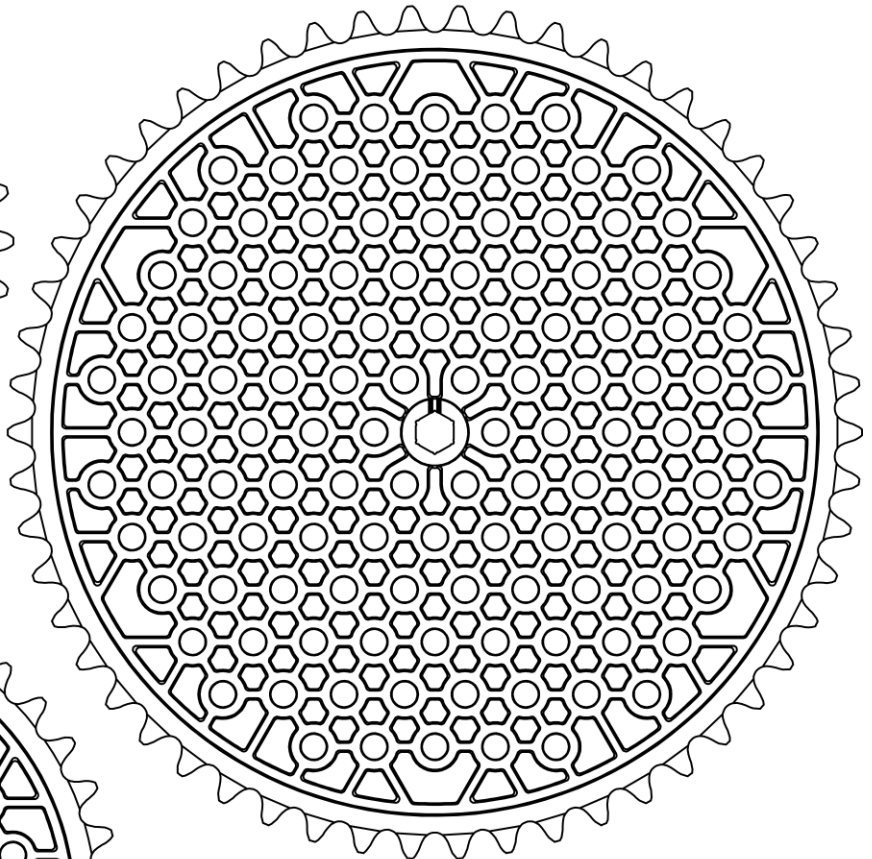

REV-41-1341
54 Tooth Sprocket

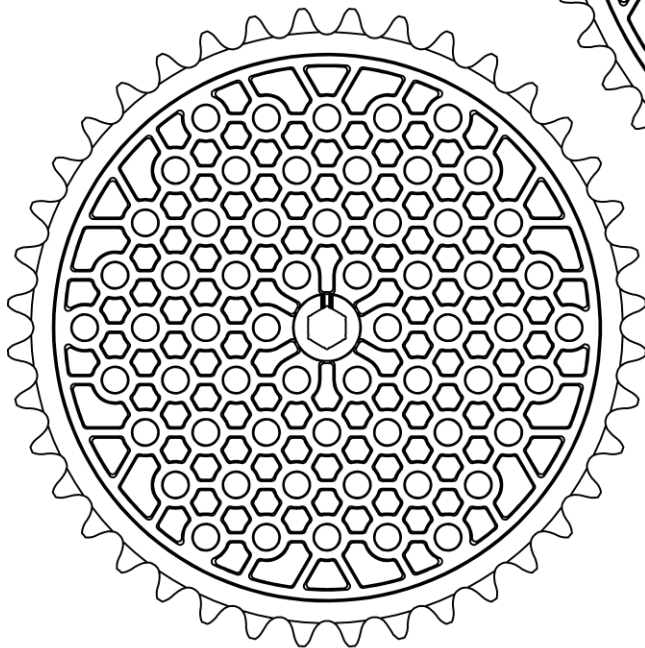

REV-41-1343
40 Tooth Sprocket

4.3 TRACTION WHEELS (1:1)

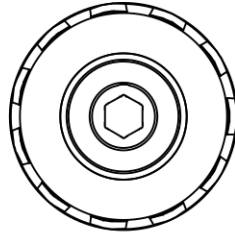

REV-41-1353
30mm Traction Wheel

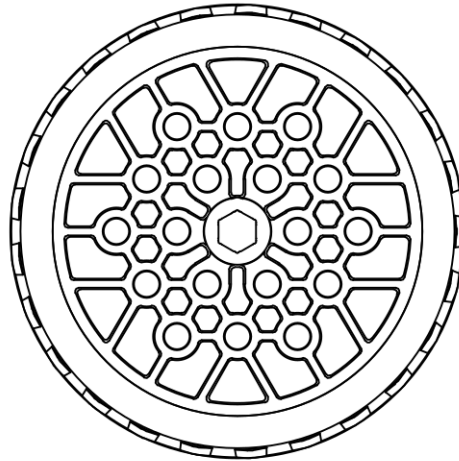

REV-41-1350
60mm Traction Wheel

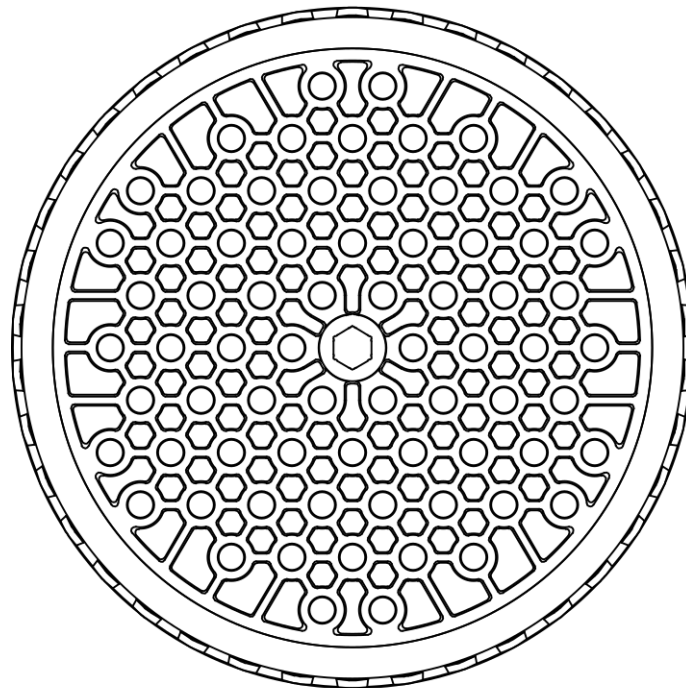

REV-41-1354
90mm Traction Wheel

4.4 BRACKETS (1:1)

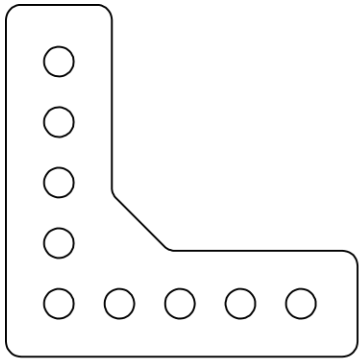

REV-41-1305
90° Bracket

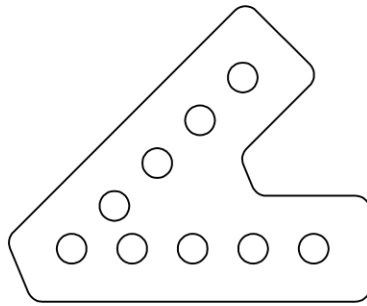

REV-41-1307
45° Bracket

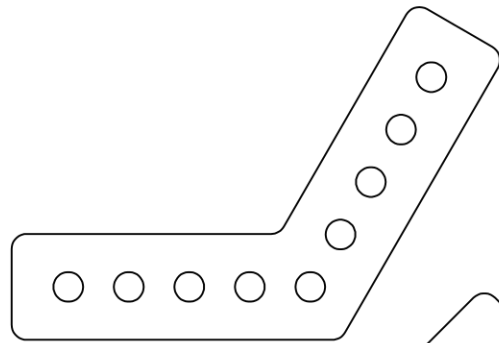

REV-41-1311
120° Bracket

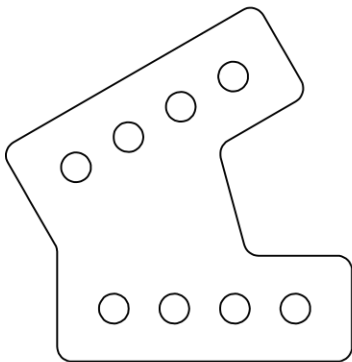

REV-41-1308
30° Bracket

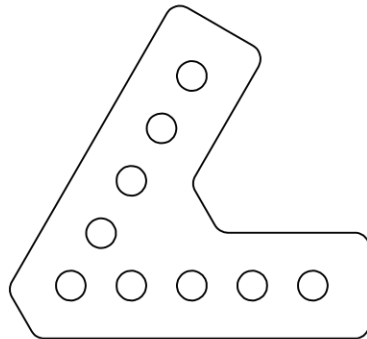

REV-41-1306
60° Bracket

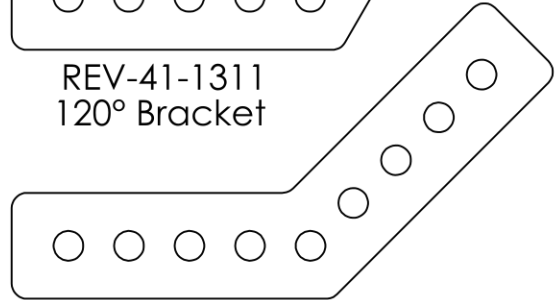

REV-41-1310
135° Bracket

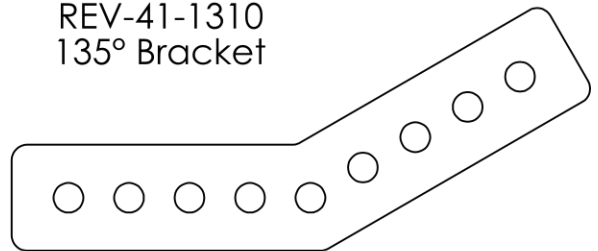

REV-41-1312
150° Bracket

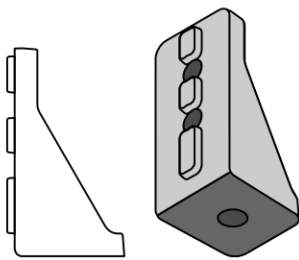

REV-41-1321
Lap Corner Bracket

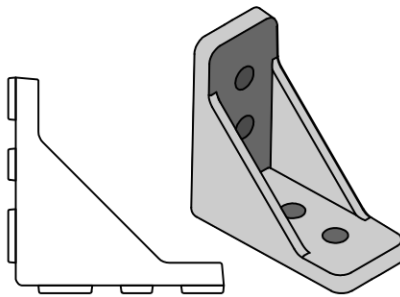

REV-41-1320
Inside Corner Bracket

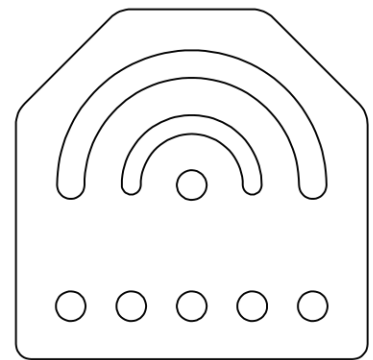

REV-41-1318
Variable Angle Bracket

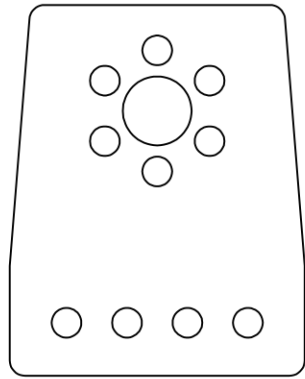

REV-41-1303
Motion Bracket

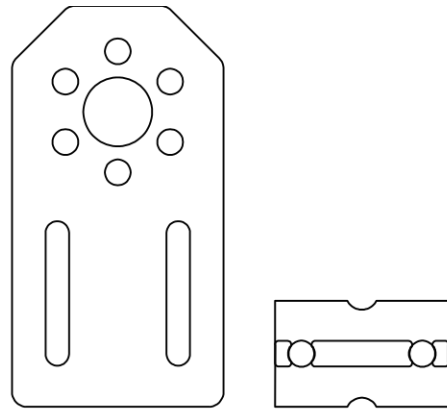

REV-41-1313
Indexable Motion Bracket

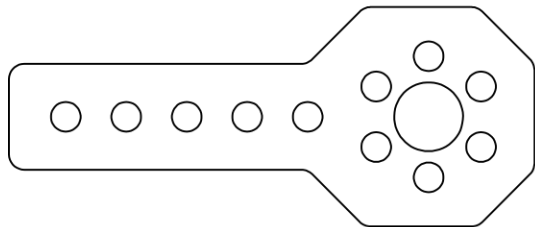

REV-41-1304
Rod End Motion Bracket

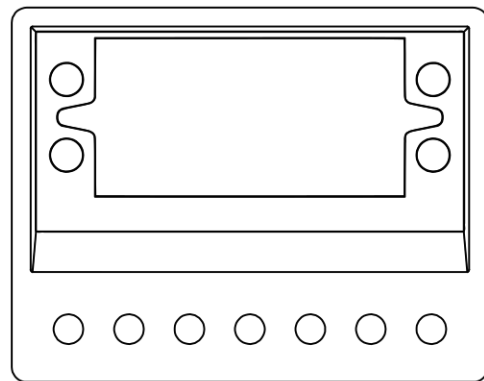

REV-41-1319
Servo Bracket

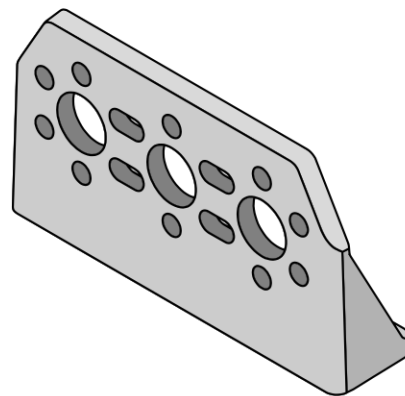
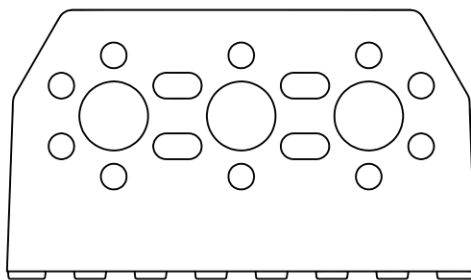

REV-41-1315
Gearbox Motion Bracket

4.5 PILLOW BLOCKS (1:1)

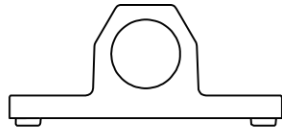

REV-41-1317
Bearing Pillow Bracket

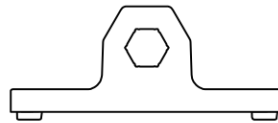

REV-41-1316
Hex Pillow Bracket

4.6 BEARINGS (1:1)

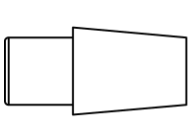

REV-41-1322
End Cap Bearing

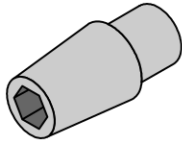

REV-41-1326
Short Through-bore Bearing

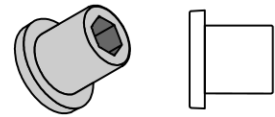

REV-41-1329
Long Through-bore Bearing

4.7 SPACERS (1:1)

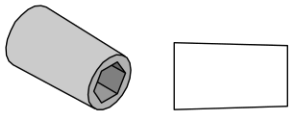

REV-41-1123
15mm Spacer



REV-41-1124
3mm Spacer



REV-41-1125
1.5mm Spacer

4.8 Adapters and Collars (1:1)

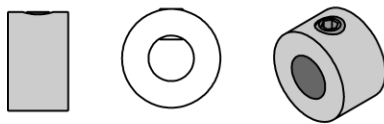

REV-41-1330
Shaft Collar

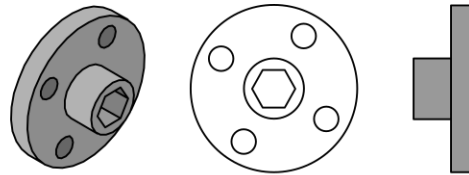

REV-41-1146
Hex Hub Adapter



REV-41-1364
Servo Gear Adapter



REV-41-1328
Servo Shaft Adapter

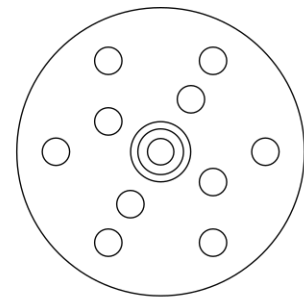

REV-41-1363
Aluminum Servo Horn