



BEARING GUIDE

This guide is intended as a reference on how to build with the new REV Robotics 15mm Building System using bearings and brackets to achieve basic motion.

TABLE OF CONTENTS

1	BRACKETS	3
1.1	BRACKET FEATURES	3
1.2	ALL BRACKET TYPES.....	4
1.3	VARIABLE ANGLE BRACKET	5
1.4	INDEXABLE MOTION BRACKET	5
2	BEARINGS	6
2.1	BEARING FEATURES.....	6
2.2	BEARING TYPES.....	6
2.3	BEARING EXAMPLES	7

1 BRACKETS

1.1 BRACKET FEATURES

Plastic brackets are nominally 3mm thick and made from molded nylon (PA66). Figure 1 lists key features of the Plastic Brackets for the REV Robotics 15mm Extrusion System. Check individual product CAD models for exact dimensions for each bracket.

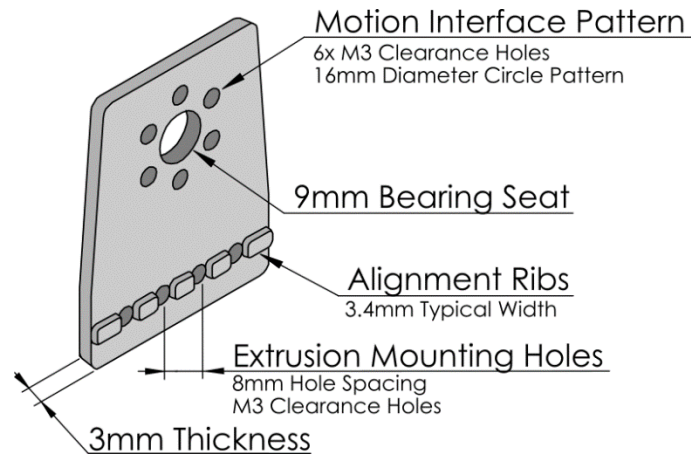

Figure 1: Motion Bracket Feature Details

Alignment Ribs: Protrusions on one side of the bracket seat into the extrusion channel and help align the bracket to the extrusion and add strength and rigidity to joints.

Extrusion Mounting Holes: M3 Mounting holes are on an 8mm pitch.

Bearing Seat: Brackets with a 9mm hole can be used to mate with any of the plastic bearings to support a shaft.

Motion Interface Mounting Pattern: Circular M3 hole pattern on a 16mm diameter is used to mount to REV Robotics shaft accessories.

1.2 ALL BRACKET TYPES

Table 1 and Table 2 show all of the motion and construction brackets in the REV Robotics 15mm Plastic Building System.

Table 1: Motion Brackets

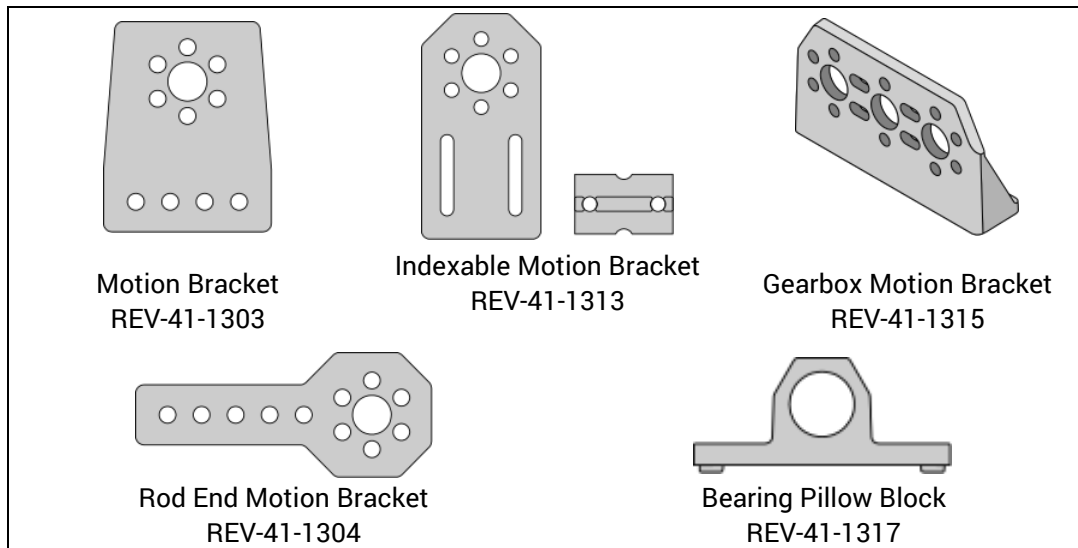
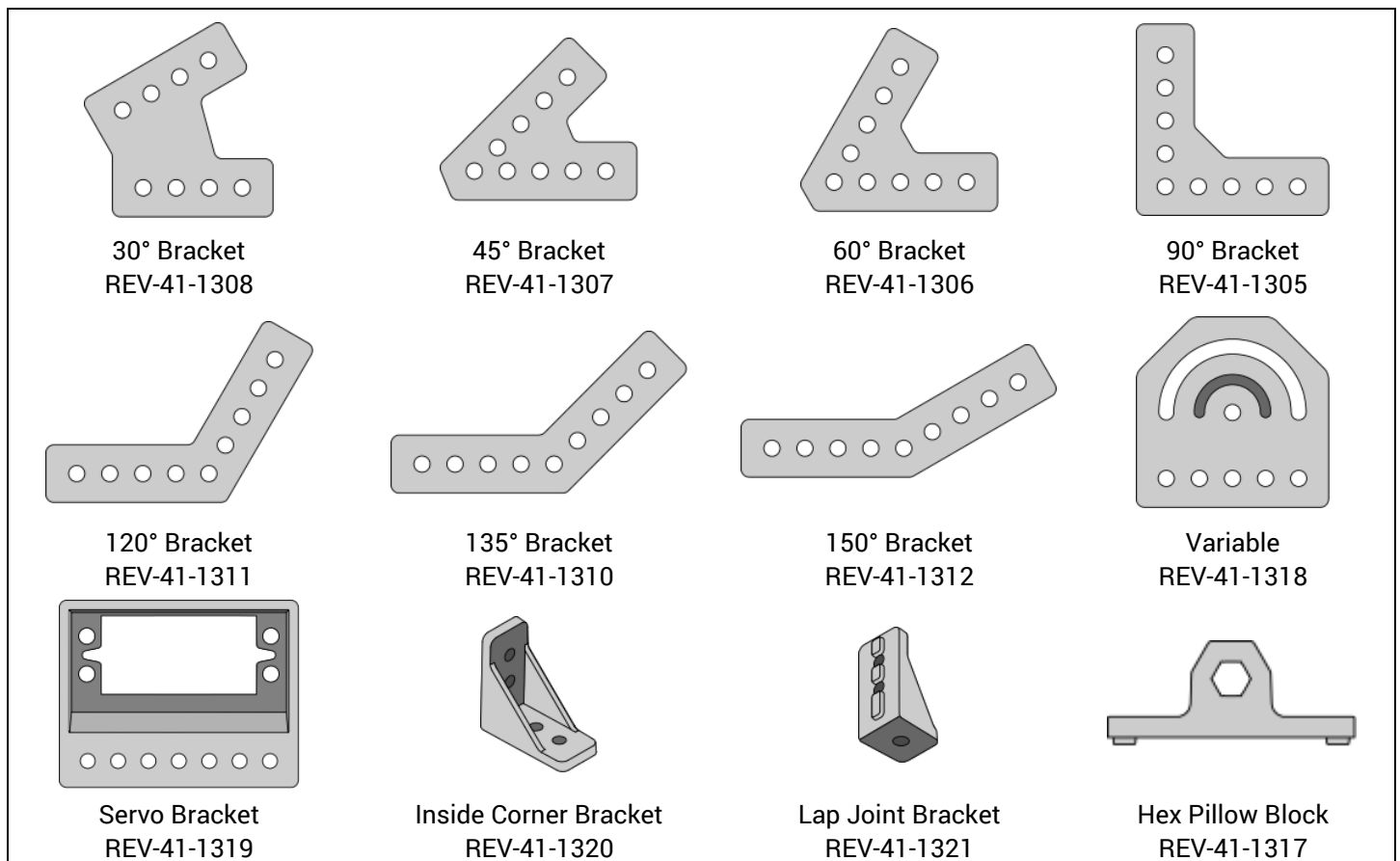

Table 2: Construction Brackets



The REV Robotics 15mm building system uses plastic nylon (PA66) molded pillow blocks. The bearing pillow block can be used with the long through-bore or end cap bearings to provide a low friction shaft support. The hex pillow block directly interfaces with a 5mm shaft which can be used to drive a light duty arm or as a dead axle support.

1.3 VARIABLE ANGLE BRACKET

The variable angle bracket is a special kind of construction bracket which allows 2 pieces of extrusion to be mounted together at any angle from 0-180° (Figure 2). For additional strength, after the ideal angle has been set, miter the end of the extrusion which will be connected using the arced slot and drill a hole along the alignment mark arc so that it lines up with the extrusion channel and add another bolt to fix the angle.

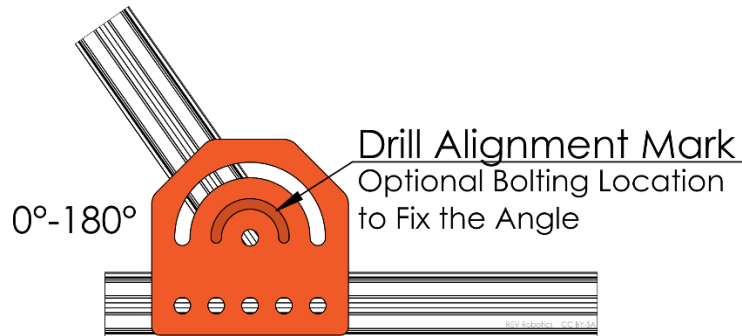

Figure 2: Adjustable Angle Bracket Example

1.4 INDEXABLE MOTION BRACKET

The Indexable Motion Bracket is a specialized version of the Motion Bracket. This bracket is made up of two pieces: the smaller piece has alignment ribs and fits onto the extrusion, while the larger piece has a motion interface pattern and a bearing seat (Figure 3). On the inside face, where these brackets meet is a fine sawtooth pattern which mesh when they are bolted together to hold the shaft offset. To adjust the offset, loosen the bolts and adjust as needed, retighten with the teeth fully engaged to resecure (Figure 4).

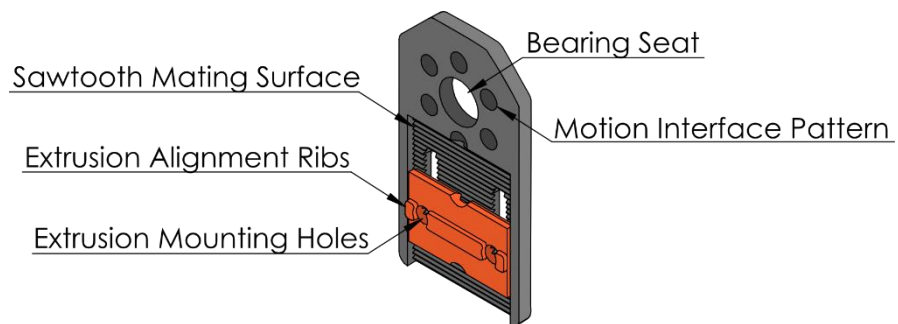

Figure 3: Indexable Motion Bracket

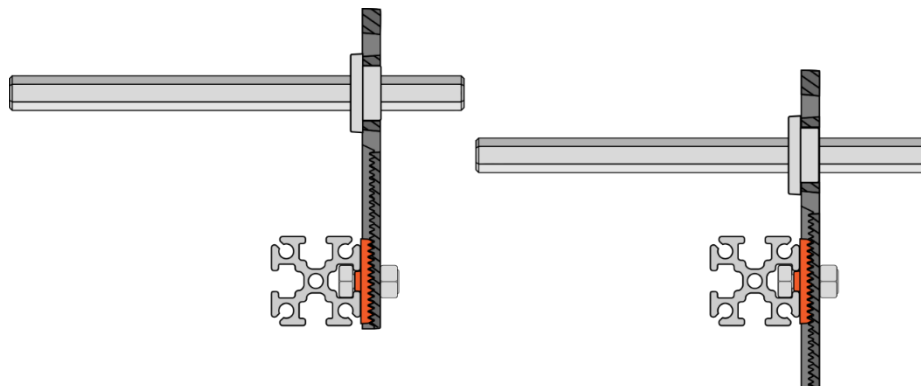

Figure 4: Shaft Offset Using an Indexable Bracket

2 BEARINGS

2.1 BEARING FEATURES

The REV Robotics 15mm Extrusion Building System uses plastic acetal (Delrin/POM) molded bearings. These bearings have a maximum 9mm outer diameter (OD) which fit inside the 9mm inner diameter (ID) hole in the all the motion brackets (Figure 5).

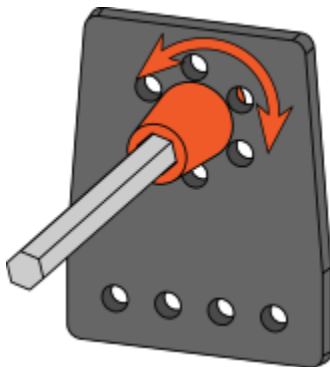

Figure 5: Plastic Bearing in a Motion Bracket

These Delrin bearings provide stable, low friction axle support in our nylon brackets. The two materials were carefully chosen because they have a very low coefficient of friction and are also incompatible materials, meaning that they will not stick together under extreme heat.

2.2 BEARING TYPES

REV Robotics Bearings come in three varieties (Table 3).

Table 3: Bearings



End cap bearings are closed on one end, so when these bearings are placed on both ends of a shaft and fit into motion brackets the shaft is free to rotate but is fully constrained laterally (sideways).

Short Through-bore Bearings are low profile pass through bearings intended to seat directly into any of the motion brackets. These low profile bearings have a 3mm contact surface which makes them flush with one side of the motion plate. Shaft collars are recommended to laterally constrain the shaft.

Long Through-bore Bearings are full depth bearings which can be used with any of the motion brackets or the bearing pillow block. Unlike the end cap bearing, because a shaft can pass through this bearing it can be used with the bearing pillow block to have a pivot between two fixed shaft ends. Shaft collars are recommended to laterally constrain the shaft.

There are number of different bearing, shaft collar, and motion bracket combinations that are recommended. See Figure 6 for a visual representation of some of the recommended combinations.

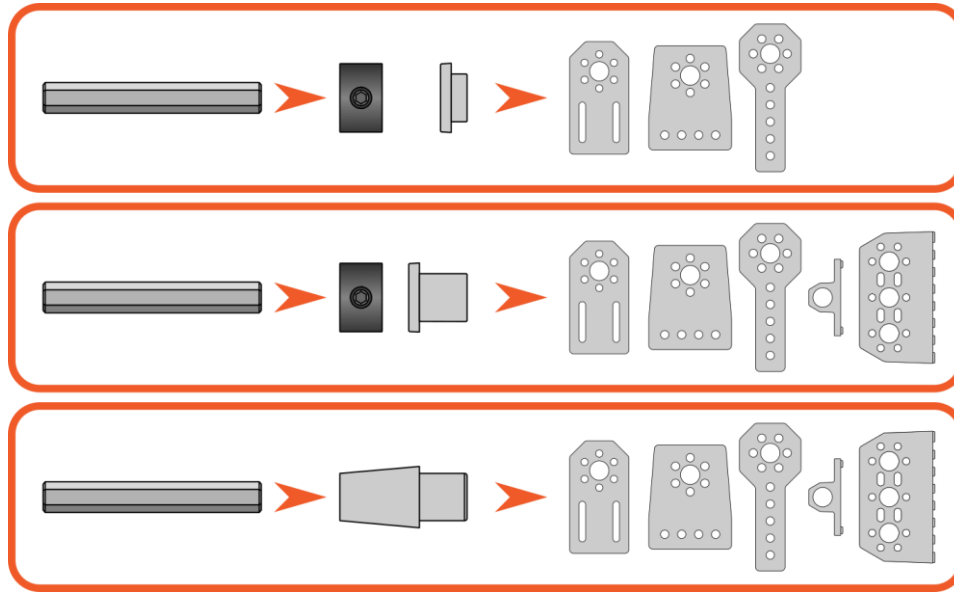

Figure 6: Bearing Assembly Combination Recommendations

2.3 BEARING EXAMPLES

Figure 7 - Figure 10 shows several possible combinations for bearings, motion brackets, and pillow blocks. In these figures the brackets are all depicted as facing “up” but brackets can also point “down” just as well.

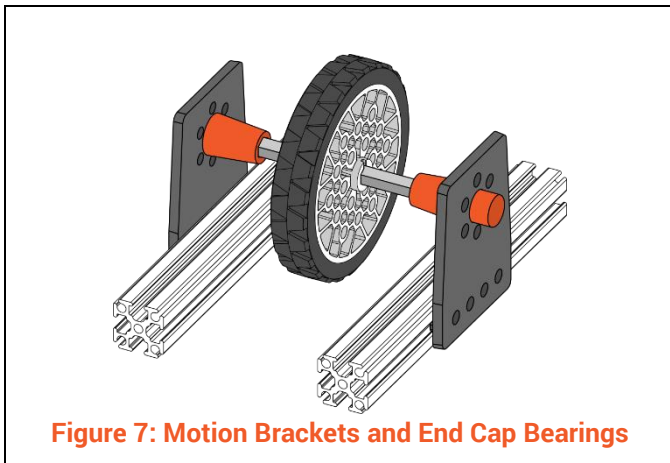

Figure 7: Motion Brackets and End Cap Bearings

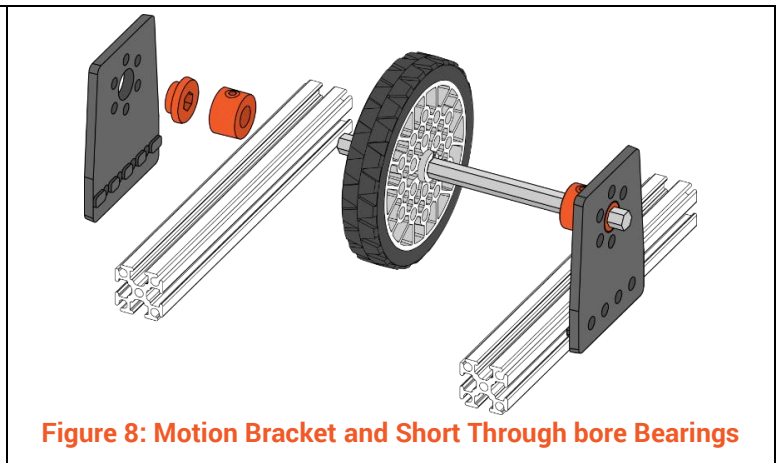

Figure 8: Motion Bracket and Short Through bore Bearings

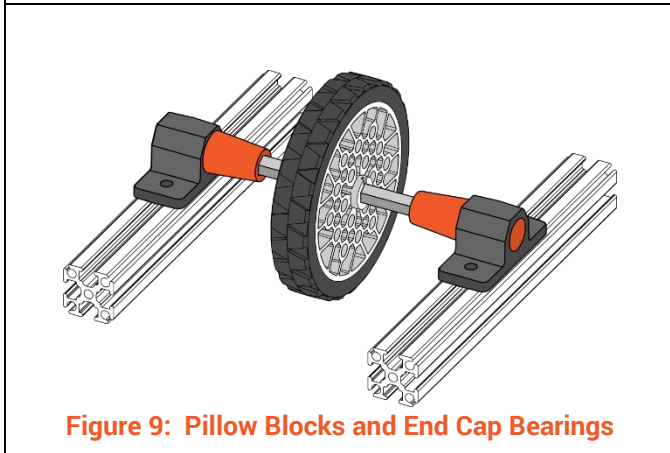

Figure 9: Pillow Blocks and End Cap Bearings

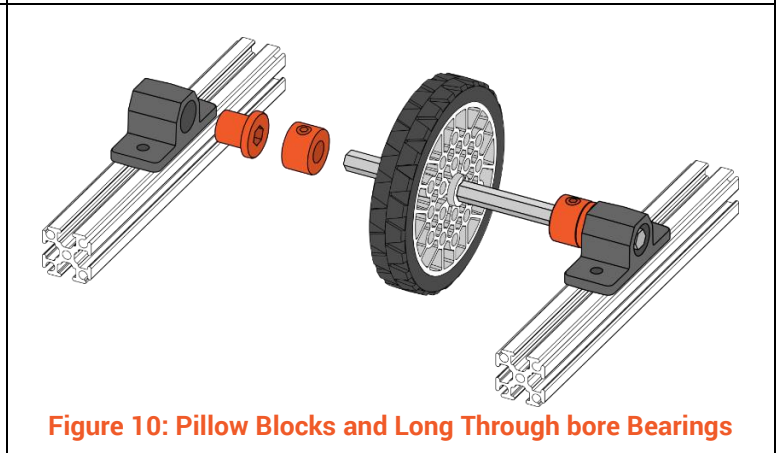

Figure 10: Pillow Blocks and Long Through bore Bearings