

# AP<sup>®</sup> Chemistry Practice Exam

---

From the 2014 Administration

**NOTE:** This is a modified version of the 2014 AP Chemistry Exam.

This Practice Exam is provided by the College Board for AP Exam preparation. Teachers are permitted to download the materials and make copies to use with their students in a classroom setting only. To maintain the security of this exam, teachers should collect all materials after their administration and keep them in a secure location. **Exams may not be posted on school or personal websites, nor electronically redistributed for any reason.** Further distribution of these materials outside of the secure College Board site disadvantages teachers who rely on uncirculated questions for classroom testing. Any additional distribution is in violation of the College Board's copyright policies and may result in the termination of Practice Exam access for your school as well as the removal of access to other online services such as the AP Teacher Community and Online Score Reports.

# Contents

Exam Instructions

Student Answer Sheet for the Multiple-Choice Section

Section I: Multiple-Choice Questions

Section II: Free-Response Questions

Multiple-Choice Answer Key

Free-Response Scoring Guidelines

Scoring Worksheet

Note: This publication shows the page numbers that appeared in the *2013–14 AP Exam Instructions* book and in the actual exam. This publication was not repaginated to begin with page 1.

---

## Exam Instructions

The following contains instructions taken from the *2013–14 AP Exam Instructions* book.

# AP<sup>®</sup> Chemistry Exam

Regularly Scheduled Exam Date: Monday morning, May 5, 2014

Late-Testing Exam Date: Thursday afternoon, May 22, 2014

Section I Total Time: 1 hr. 30 min.    Section II Total Time: 1 hr. 30 min.

## What Proctors Need to Bring to This Exam

- Exam packets
- Answer sheets
- AP Student Packs
- *2013-14 AP Coordinator's Manual*
- This book — *AP Exam Instructions*
- School Code and Home-School/Self-Study Codes
- Extra calculators
- Pencil sharpener
- Extra No. 2 pencils with erasers
- Extra pens with black or dark blue ink
- Extra paper
- Stapler
- Watch
- Signs for the door to the testing room
  - “Exam in Progress”
  - “Cell phones are prohibited in the testing room”

Note: this year, tables of equations and constants are provided in the exam booklets for both sections of the exam.

Students are not allowed to use calculators in Section I of the AP Chemistry Exam. However, students are permitted to use four-function, scientific, or graphing calculators to answer questions in Section II. Before starting the exam administration, make sure that each student has an appropriate calculator and that any student with a graphing calculator has a model from the approved list on page 45 of the *2013-14 AP Coordinator's Manual*. See pages 42–45 of the *2013-14 AP Coordinator's Manual* for more information. If a student does not have an appropriate calculator or has a graphing calculator not on the approved list, you may provide one from your supply. If the student does not want to use the calculator you provide, or does not want to use a calculator at all, he or she must hand copy, date, and sign the release statement on page 43 of the *2013-14 AP Coordinator's Manual*.

During the administration of Section II students may have no more than two calculators on their desks. Calculators may not be shared. Calculator memories do not need to be cleared before or after the exam. Students with Hewlett-Packard 48–50 Series and Casio FX-9860 graphing calculators may use cards designed for use with these calculators. Proctors should make sure infrared ports (Hewlett-Packard) are not facing each other. **Since graphing calculators can be used to store data, including text, proctors should monitor that students are using their calculators appropriately. Attempts by students to use the calculator to remove exam questions and/or answers from the room may result in the cancellation of AP Exam scores.**

Students will be allowed to use the table of equations and constants on both sections of the exam.

## SECTION I: Multiple Choice

- **Do not begin the exam instructions below until you have completed the appropriate**
- **General Instructions for your group.**

Make sure you begin the exam at the designated time.

*If you are giving the regularly scheduled exam, say:*

**It is Monday morning, May 5, and you will be taking the AP Chemistry Exam.**

*If you are giving the alternate exam for late testing, say:*

**It is Thursday afternoon, May 22, and you will be taking the AP Chemistry Exam.**

**In a moment, you will open the packet that contains your exam materials. By opening this packet, you agree to all of the AP Program’s policies and procedures outlined in the *2013-14 Bulletin for AP Students and Parents*. You may now remove the shrinkwrap from your exam packet and take out the Section I booklet, but do not open the booklet or the shrinkwrapped Section II materials. Put the white seals aside. . . .**

**Carefully remove the AP Exam label found near the top left of your exam booklet cover. Now place it on page 1 of your answer sheet on the light blue box near the top right-hand corner that reads “AP Exam Label.”**

If students accidentally place the exam label in the space for the number label or vice versa, advise them to leave the labels in place. They should not try to remove the label; their exam will be processed correctly.

**Read the statements on the front cover of Section I and look up when you have finished. . . .**

**Sign your name, and write today’s date. Look up when you have finished. . . .**

**Now print your full legal name where indicated. Are there any questions? . . .**

**Turn to the back cover and read it completely. Look up when you have finished. . . .**

**Are there any questions? . . .**

**Section I is the multiple-choice portion of the exam. You may never discuss these specific multiple-choice questions at any time in any form with anyone, including your teacher and other students. If you disclose these questions through any means, your AP Exam score will be canceled. Are there any questions? . . .**

**You must complete the answer sheet using a No. 2 pencil only. Mark all of your responses beginning on page 2 of your answer sheet, one response per question. Completely fill in the circles. If you need to erase, do so carefully and completely. No credit will be given for anything written in the exam booklet. Scratch paper is not allowed, but you may use the margins or any blank space in the exam booklet for scratch work. Calculators are not allowed for this section. Please put your calculators under your chair. Are there any questions? . . .**

**You have 1 hour and 30 minutes for this section. Open your Section I booklet and begin.**



Note Start Time here \_\_\_\_\_. Note Stop Time here \_\_\_\_\_. Check that students are marking their answers in pencil on their answer sheets, and that they are not looking at their shrinkwrapped Section II booklets. After 1 hour and 30 minutes, say:

**Stop working. Close your booklet and put your answer sheet on your desk, face up. Make sure you have your AP number label and an AP Exam label on page 1 of your answer sheet. I will now collect your answer sheet.**

Collect an answer sheet from each student. Check that each answer sheet has an AP number label and an AP Exam label. Then say:

**Now you must seal your exam booklet. Remove the white seals from the backing and press one on each area of your exam booklet cover marked "PLACE SEAL HERE." Fold each seal over the back cover. When you have finished, place the booklet on your desk, face up. I will now collect your Section I booklet. . . .**

Collect a Section I booklet from each student. Check that each student has signed the front cover of the sealed Section I booklet.

There is a 10-minute break between Sections I and II. When all Section I materials have been collected and accounted for and you are ready for the break, say:

**Please listen carefully to these instructions before we take a 10-minute break. Everything you placed under your chair at the beginning of the exam must stay there. Leave your shrinkwrapped Section II packet on top of your desk during the break. You are not allowed to consult teachers, other students, or textbooks about the exam during the break. You may not make phone calls, send text messages, check email, use a social networking site, or access any electronic or communication device. Remember, you are not allowed to discuss the multiple-choice section of this exam. If you do not follow these rules, your score could be canceled. Are there any questions? . . .**



You may begin your break. Testing will resume at \_\_\_\_\_.

## SECTION II: Free Response

After the break, say:

**May I have everyone's attention? Place your Student Pack on your desk. . . .**

**You may now remove the shrinkwrap from the Section II packet, but do not open the exam booklet until you are told to do so. . . .**

**Read the bulleted statements on the front cover of the exam booklet. Look up when you have finished. . . .**

**Now place an AP number label on the shaded box. If you don't have any AP number labels, write your AP number in the box. Look up when you have finished. . . .**

**Read the last statement. . . .**

Using your pen, print the first, middle and last initials of your legal name in the boxes and print today's date where indicated. This constitutes your signature and your agreement to the statements on the front cover. . . .

Turn to the back cover and complete Item 1 under "Important Identification Information." Print the first two letters of your last name and the first letter of your first name in the boxes. Look up when you have finished. . . .

In Item 2, print your date of birth in the boxes. . . .

In Item 3, write the school code you printed on the front of your Student Pack in the boxes. . . .

Read Item 4. . . .

Are there any questions? . . .

I need to collect the Student Pack from anyone who will be taking another AP Exam. You may keep it only if you are not taking any other AP Exams this year. If you have no other AP Exams to take, place your Student Pack under your chair now. . . .

While Student Packs are being collected, read the information on the back cover of the exam booklet. Do not open the exam booklet until you are told to do so. Look up when you have finished. . . .

Collect the Student Packs. Then say:

Are there any questions? . . .

Calculators may be used for Section II. You may get your calculators from under your chair and place them on your desk. . . .

You have 1 hour and 30 minutes to complete Section II. You are responsible for pacing yourself, and you may proceed freely from one question to the next. You must write your answers in the exam booklet using a pen with black or dark blue ink or a No. 2 pencil. If you use a pencil, be sure that your writing is dark enough to be easily read. If you need more paper during the exam, raise your hand. At the top of each extra piece of paper you use, be sure to write only your AP number and the number of the question you are working on. Do not write your name. Are there any questions? . . .

You may begin.



Note Start Time here \_\_\_\_\_. Note Stop Time here \_\_\_\_\_. Check that students are writing their answers in their exam booklets. Proctors should also make sure that Hewlett-Packard calculators' infrared ports are not facing each other and that students are not sharing calculators. After 1 hour and 20 minutes, say:

**There are 10 minutes remaining.**

After 10 minutes, say:

**Stop working and close your exam booklet. Place it on your desk, face up. . . .**

If any students used extra paper for the free-response section, have those students staple the extra sheet/s to the first page corresponding to that question in their exam booklets. Then say:

**Remain in your seat, without talking, while the exam materials are collected. . . .**

Collect a Section II booklet from each student. Check for the following:

- Exam booklet front cover: The student placed an AP number label on the shaded box, and printed his or her initials and today's date.
- Exam booklet back cover: The student completed the "Important Identification Information" area.

When all exam materials have been collected and accounted for, return to students any electronic devices you may have collected before the start of the exam.

*If you are giving the regularly scheduled exam, say:*

**You may not discuss or share these specific free-response questions with anyone unless they are released on the College Board website in about two days. Your AP score results will be available online in July.**

*If you are giving the alternate exam for late testing, say:*

**None of the questions in this exam may ever be discussed or shared in any way at any time. Your AP score results will be available online in July.**

If any students completed the AP number card at the beginning of this exam, say:

**Please remember to take your AP number card with you. You will need the information on this card to view your scores and order AP score reporting services online.**

Then say:

**You are now dismissed.**

All exam materials should be put in secure storage until they are returned to the AP Program after your school's last administration. Before storing materials, check the "School Use Only" section on page 1 of the answer sheet and:

- Fill in the appropriate section number circle in order to access a separate AP Instructional Planning Report (for regularly scheduled exams only) or subject score roster at the class section or teacher level. See "Post-Exam Activities" in the *2013-14 AP Coordinator's Manual*.
- Check your list of students who are eligible for fee reductions and fill in the appropriate circle on their registration answer sheets.



---

## **Student Answer Sheet for the Multiple-Choice Section**

Use this section to capture student responses. (Note that the following answer sheet is a sample, and may differ from one used in an actual exam.)



COMPLETE THIS AREA AT EACH EXAM (IF APPLICABLE)

**O. SURVEY QUESTIONS** — Answer the survey questions in the AP Student Pack. Do not put responses to exam questions in this section.

- 1 (A) (B) (C) (D) (E) (F) (G) (H) (I)
- 2 (A) (B) (C) (D) (E) (F) (G) (H) (I)
- 3 (A) (B) (C) (D) (E) (F) (G) (H) (I)

- 4 (A) (B) (C) (D) (E) (F) (G) (H) (I)
- 5 (A) (B) (C) (D) (E) (F) (G) (H) (I)
- 6 (A) (B) (C) (D) (E) (F) (G) (H) (I)

- 7 (A) (B) (C) (D) (E) (F) (G) (H) (I)
- 8 (A) (B) (C) (D) (E) (F) (G) (H) (I)
- 9 (A) (B) (C) (D) (E) (F) (G) (H) (I)

**P. LANGUAGE** — Do not complete this section unless instructed to do so.

If this answer sheet is for the French Language and Culture, German Language and Culture, Italian Language and Culture, Spanish Language and Culture, or Spanish Literature and Culture Exam, please answer the following questions. Your responses will not affect your score.

1. Have you lived or studied for one month or more in a country where the language of the exam you are now taking is spoken?

- Yes
- No

2. Do you regularly speak or hear the language at home?

- Yes
- No

**QUESTIONS 1–75**

Indicate your answers to the exam questions in this section (pages 2 and 3). Mark only one response per question. If a question has only four answer options, do not mark option E. Answers written in the multiple-choice booklet will not be scored.

COMPLETE MARK ●

EXAMPLES OF INCOMPLETE MARKS



You must use a No. 2 pencil and marks must be complete. Do not use a mechanical pencil. It is very important that you fill in the entire circle darkly and completely. If you change your response, erase as completely as possible. Incomplete marks or erasures may affect your score.

- 1 (A) (B) (C) (D) (E)
- 2 (A) (B) (C) (D) (E)
- 3 (A) (B) (C) (D) (E)
- 4 (A) (B) (C) (D) (E)
- 5 (A) (B) (C) (D) (E)
- 6 (A) (B) (C) (D) (E)
- 7 (A) (B) (C) (D) (E)
- 8 (A) (B) (C) (D) (E)
- 9 (A) (B) (C) (D) (E)
- 10 (A) (B) (C) (D) (E)
- 11 (A) (B) (C) (D) (E)
- 12 (A) (B) (C) (D) (E)
- 13 (A) (B) (C) (D) (E)
- 14 (A) (B) (C) (D) (E)
- 15 (A) (B) (C) (D) (E)
- 16 (A) (B) (C) (D) (E)
- 17 (A) (B) (C) (D) (E)
- 18 (A) (B) (C) (D) (E)
- 19 (A) (B) (C) (D) (E)
- 20 (A) (B) (C) (D) (E)
- 21 (A) (B) (C) (D) (E)
- 22 (A) (B) (C) (D) (E)
- 23 (A) (B) (C) (D) (E)
- 24 (A) (B) (C) (D) (E)
- 25 (A) (B) (C) (D) (E)

- 26 (A) (B) (C) (D) (E)
- 27 (A) (B) (C) (D) (E)
- 28 (A) (B) (C) (D) (E)
- 29 (A) (B) (C) (D) (E)
- 30 (A) (B) (C) (D) (E)
- 31 (A) (B) (C) (D) (E)
- 32 (A) (B) (C) (D) (E)
- 33 (A) (B) (C) (D) (E)
- 34 (A) (B) (C) (D) (E)
- 35 (A) (B) (C) (D) (E)
- 36 (A) (B) (C) (D) (E)
- 37 (A) (B) (C) (D) (E)
- 38 (A) (B) (C) (D) (E)
- 39 (A) (B) (C) (D) (E)
- 40 (A) (B) (C) (D) (E)
- 41 (A) (B) (C) (D) (E)
- 42 (A) (B) (C) (D) (E)
- 43 (A) (B) (C) (D) (E)
- 44 (A) (B) (C) (D) (E)
- 45 (A) (B) (C) (D) (E)
- 46 (A) (B) (C) (D) (E)
- 47 (A) (B) (C) (D) (E)
- 48 (A) (B) (C) (D) (E)
- 49 (A) (B) (C) (D) (E)
- 50 (A) (B) (C) (D) (E)

- 51 (A) (B) (C) (D) (E)
- 52 (A) (B) (C) (D) (E)
- 53 (A) (B) (C) (D) (E)
- 54 (A) (B) (C) (D) (E)
- 55 (A) (B) (C) (D) (E)
- 56 (A) (B) (C) (D) (E)
- 57 (A) (B) (C) (D) (E)
- 58 (A) (B) (C) (D) (E)
- 59 (A) (B) (C) (D) (E)
- 60 (A) (B) (C) (D) (E)
- 61 (A) (B) (C) (D) (E)
- 62 (A) (B) (C) (D) (E)
- 63 (A) (B) (C) (D) (E)
- 64 (A) (B) (C) (D) (E)
- 65 (A) (B) (C) (D) (E)
- 66 (A) (B) (C) (D) (E)
- 67 (A) (B) (C) (D) (E)
- 68 (A) (B) (C) (D) (E)
- 69 (A) (B) (C) (D) (E)
- 70 (A) (B) (C) (D) (E)
- 71 (A) (B) (C) (D) (E)
- 72 (A) (B) (C) (D) (E)
- 73 (A) (B) (C) (D) (E)
- 74 (A) (B) (C) (D) (E)
- 75 (A) (B) (C) (D) (E)



DO NOT WRITE IN THIS AREA







---

## Section I: Multiple-Choice Questions

This is the multiple-choice section of the 2014 AP exam.  
It includes cover material and other administrative instructions  
to help familiarize students with the mechanics of the exam.  
(Note that future exams may differ in look from the following content.)

PLACE SEAL HERE

# AP<sup>®</sup> Chemistry Exam

## SECTION I: Multiple Choice

2014

**DO NOT OPEN THIS BOOKLET UNTIL YOU ARE TOLD TO DO SO.**

### At a Glance

**Total Time**

1 hour, 30 minutes

**Number of Questions**

50

**Percent of Total Score**

50%

**Writing Instrument**

Pencil required

**Electronic Device**

None allowed

### Instructions

Section I of this exam contains 50 multiple-choice questions. Fill in only the circles for numbers 1 through 50 on your answer sheet. Pages containing a periodic table and lists containing equations and constants are also printed in this booklet.

Indicate all of your answers to the multiple-choice questions on the answer sheet. No credit will be given for anything written in this exam booklet, but you may use the booklet for notes or scratch work. After you have decided which of the suggested answers is best, completely fill in the corresponding circle on the answer sheet.

Because this section offers only four answer options for each question, do not mark the (E) answer circle for any question. Give only one answer to each question. If you change an answer, be sure that the previous mark is erased completely. Here is a sample question and answer.

Sample Question      Sample Answer

Chicago is a      (A) ● (C) (D) (E)  
(A) state  
(B) city  
(C) country  
(D) continent

Use your time effectively, working as quickly as you can without losing accuracy. Do not spend too much time on any one question. Go on to other questions and come back to the ones you have not answered if you have time. It is not expected that everyone will know the answers to all of the multiple-choice questions.

Your total score on Section I is based only on the number of questions answered correctly. Points are not deducted for incorrect answers or unanswered questions.

PLACE SEAL HERE

PLACE SEAL HERE

DO NOT seal answer sheet inside

DO NOT DETACH FROM BOOK.

## PERIODIC TABLE OF THE ELEMENTS

1	<b>H</b>											2	<b>He</b>										
	1.008												4.00										
3		4											9										
	<b>Li</b>	<b>Be</b>											<b>F</b>	<b>Ne</b>									
	6.94	9.01											19.00	20.18									
11		12											17	18									
	<b>Na</b>	<b>Mg</b>											<b>Cl</b>	<b>Ar</b>									
	22.99	24.30											35.45	39.95									
19		20	21	22	23	24	25	26	27	28	29	30	31	32	33	34	35	36					
	<b>K</b>	<b>Ca</b>	<b>Sc</b>	<b>Ti</b>	<b>V</b>	<b>Cr</b>	<b>Mn</b>	<b>Fe</b>	<b>Co</b>	<b>Ni</b>	<b>Cu</b>	<b>Zn</b>	<b>Ga</b>	<b>Ge</b>	<b>As</b>	<b>Se</b>	<b>Br</b>	<b>Kr</b>					
	39.10	40.08	44.96	47.90	50.94	52.00	54.94	55.85	58.93	58.69	63.55	65.39	69.72	72.59	74.92	78.96	79.90	83.80					
37		38	39	40	41	42	43	44	45	46	47	48	49	50	51	52	53	54					
	<b>Rb</b>	<b>Sr</b>	<b>Y</b>	<b>Zr</b>	<b>Nb</b>	<b>Mo</b>	<b>Tc</b>	<b>Ru</b>	<b>Rh</b>	<b>Pd</b>	<b>Ag</b>	<b>Cd</b>	<b>In</b>	<b>Sn</b>	<b>Sb</b>	<b>Te</b>	<b>I</b>	<b>Xe</b>					
	85.47	87.62	88.91	91.22	92.91	95.94	(98)	101.1	102.91	106.42	107.87	112.41	114.82	118.71	121.75	127.60	126.91	131.29					
55		56	57	72	73	74	75	76	77	78	79	80	81	82	83	84	85	86					
	<b>Cs</b>	<b>Ba</b>	<b>*La</b>	<b>Hf</b>	<b>Ta</b>	<b>W</b>	<b>Re</b>	<b>Os</b>	<b>Ir</b>	<b>Pt</b>	<b>Au</b>	<b>Hg</b>	<b>Tl</b>	<b>Pb</b>	<b>Bi</b>	<b>Po</b>	<b>At</b>	<b>Rn</b>					
	132.91	137.33	138.91	178.49	180.95	183.85	186.21	190.2	192.2	195.08	196.97	200.59	204.38	207.2	208.98	(209)	(210)	(222)					
87		88	89	104	105	106	107	108	109	110	111												
	<b>Fr</b>	<b>Ra</b>	<b>†Ac</b>	<b>Rf</b>	<b>Db</b>	<b>Sg</b>	<b>Bh</b>	<b>Hs</b>	<b>Mt</b>	<b>Ds</b>	<b>Rg</b>												
	(223)	226.02	227.03	(261)	(262)	(266)	(264)	(277)	(268)	(271)	(272)												
													66	67	68	69	70	71					
													<b>Dy</b>	<b>Ho</b>	<b>Er</b>	<b>Tm</b>	<b>Yb</b>	<b>Lu</b>					
													162.50	164.93	167.26	168.93	173.04	174.97					
													98	99	100	101	102	103					
													<b>Cf</b>	<b>Es</b>	<b>Fm</b>	<b>Md</b>	<b>No</b>	<b>Lr</b>					
													(251)	(252)	(257)	(258)	(259)	(262)					
													65	64	63	62	61	60	59	58			
													<b>Tb</b>	<b>Gd</b>	<b>Eu</b>	<b>Sm</b>	<b>Pm</b>	<b>Nd</b>	<b>Pr</b>	<b>Ce</b>			
													158.93	157.25	151.97	150.4	(145)	144.24	140.91	140.12			
													97	96	95	94	93	92	91	90			
													<b>Bk</b>	<b>Cm</b>	<b>Am</b>	<b>Pu</b>	<b>Np</b>	<b>U</b>	<b>Pa</b>	<b>Th</b>			
													(247)	(247)	(243)	(244)	(237)	238.03	231.04	232.04			
													*Lanthanide Series			†Actinide Series							



# AP<sup>®</sup> CHEMISTRY EQUATIONS AND CONSTANTS

Throughout the exam the following symbols have the definitions specified unless otherwise noted.

L, mL = liter(s), milliliter(s)

g = gram(s)

nm = nanometer(s)

atm = atmosphere(s)

mm Hg = millimeters of mercury

J, kJ = joule(s), kilojoule(s)

V = volt(s)

mol = mole(s)

## ATOMIC STRUCTURE

$$E = h\nu$$

$$c = \lambda\nu$$

$E$  = energy

$\nu$  = frequency

$\lambda$  = wavelength

Planck's constant,  $h = 6.626 \times 10^{-34}$  J s

Speed of light,  $c = 2.998 \times 10^8$  m s<sup>-1</sup>

Avogadro's number =  $6.022 \times 10^{23}$  mol<sup>-1</sup>

Electron charge,  $e = -1.602 \times 10^{-19}$  coulomb

## EQUILIBRIUM

$$K_c = \frac{[C]^c [D]^d}{[A]^a [B]^b}, \text{ where } a A + b B \rightleftharpoons c C + d D$$

$$K_p = \frac{(P_C)^c (P_D)^d}{(P_A)^a (P_B)^b}$$

$$K_a = \frac{[H^+][A^-]}{[HA]}$$

$$K_b = \frac{[OH^-][HB^+]}{[B]}$$

$$K_w = [H^+][OH^-] = 1.0 \times 10^{-14} \text{ at } 25^\circ\text{C}$$

$$= K_a \times K_b$$

$$\text{pH} = -\log[H^+], \text{ pOH} = -\log[OH^-]$$

$$14 = \text{pH} + \text{pOH}$$

$$\text{pH} = \text{p}K_a + \log \frac{[A^-]}{[HA]}$$

$$\text{p}K_a = -\log K_a, \text{ p}K_b = -\log K_b$$

### Equilibrium Constants

$K_c$  (molar concentrations)

$K_p$  (gas pressures)

$K_a$  (weak acid)

$K_b$  (weak base)

$K_w$  (water)

## KINETICS

$$\ln[A]_t - \ln[A]_0 = -kt$$

$$\frac{1}{[A]_t} - \frac{1}{[A]_0} = kt$$

$$t_{1/2} = \frac{0.693}{k}$$

$k$  = rate constant

$t$  = time

$t_{1/2}$  = half-life

## GASES, LIQUIDS, AND SOLUTIONS

$$PV = nRT$$

$$P_A = P_{\text{total}} \times X_A, \text{ where } X_A = \frac{\text{moles A}}{\text{total moles}}$$

$$P_{\text{total}} = P_A + P_B + P_C + \dots$$

$$n = \frac{m}{M}$$

$$K = ^\circ\text{C} + 273$$

$$D = \frac{m}{V}$$

$$KE \text{ per molecule} = \frac{1}{2}mv^2$$

Molarity,  $M$  = moles of solute per liter of solution

$$A = abc$$

$P$  = pressure

$V$  = volume

$T$  = temperature

$n$  = number of moles

$m$  = mass

$M$  = molar mass

$D$  = density

$KE$  = kinetic energy

$v$  = velocity

$A$  = absorbance

$a$  = molar absorptivity

$b$  = path length

$c$  = concentration

Gas constant,  $R = 8.314 \text{ J mol}^{-1} \text{ K}^{-1}$

$$= 0.08206 \text{ L atm mol}^{-1} \text{ K}^{-1}$$

$$= 62.36 \text{ L torr mol}^{-1} \text{ K}^{-1}$$

$$1 \text{ atm} = 760 \text{ mm Hg} = 760 \text{ torr}$$

$$\text{STP} = 273.15 \text{ K and } 1.0 \text{ atm}$$

## THERMODYNAMICS / ELECTROCHEMISTRY

$$q = mc\Delta T$$

$$\Delta S^\circ = \sum S^\circ \text{ products} - \sum S^\circ \text{ reactants}$$

$$\Delta H^\circ = \sum \Delta H_f^\circ \text{ products} - \sum \Delta H_f^\circ \text{ reactants}$$

$$\Delta G^\circ = \sum \Delta G_f^\circ \text{ products} - \sum \Delta G_f^\circ \text{ reactants}$$

$$\Delta G^\circ = \Delta H^\circ - T\Delta S^\circ$$

$$= -RT \ln K$$

$$= -nFE^\circ$$

$$I = \frac{q}{t}$$

$q$  = heat

$m$  = mass

$c$  = specific heat capacity

$T$  = temperature

$S^\circ$  = standard entropy

$H^\circ$  = standard enthalpy

$G^\circ$  = standard Gibbs free energy

$n$  = number of moles

$E^\circ$  = standard reduction potential

$I$  = current (amperes)

$q$  = charge (coulombs)

$t$  = time (seconds)

Faraday's constant,  $F = 96,485$  coulombs per mole of electrons

$$1 \text{ volt} = \frac{1 \text{ joule}}{1 \text{ coulomb}}$$

**CHEMISTRY**  
**Section I**  
**50 Questions**  
**Time—90 minutes**

**CALCULATORS ARE NOT ALLOWED FOR SECTION I.**

**Note:** For all questions, assume that the temperature is 298 K, the pressure is 1.0 atm, and solutions are aqueous unless otherwise specified.

**Directions:** Each of the questions or incomplete statements below is followed by four suggested answers or completions. Select the one that is best in each case and then fill in the corresponding circle on the answer sheet.

Compound	Molar Mass (grams)
Na <sub>2</sub> O	62.0
MgO	40.3
K <sub>2</sub> O	94.2
CaO	56.1

1. According to the information in the table above, a 1.00 g sample of which of the following contains the greatest mass of oxygen?  
(A) Na<sub>2</sub>O  
(B) MgO  
(C) K<sub>2</sub>O  
(D) CaO
2. Which of the following could be the identity of a white crystalline solid that exhibits the following properties?
  - It melts at 320°C.
  - It does not conduct electricity as a solid.
  - It conducts electricity in an aqueous solution.(A) C<sub>6</sub>H<sub>12</sub>O<sub>6</sub>(s)  
(B) NaOH(s)  
(C) SiO<sub>2</sub>(s)  
(D) Cu(s)
3. Which of the following correctly identifies which has the higher first-ionization energy, Cl or Ar, and supplies the best justification?  
(A) Cl, because of its higher electronegativity  
(B) Cl, because of its higher electron affinity  
(C) Ar, because of its completely filled valence shell  
(D) Ar, because of its higher effective nuclear charge

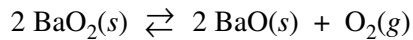

$$\Delta H^\circ = 162 \text{ kJ/mol}_{rxn}$$

4. A sealed rigid vessel contains  $\text{BaO}_2(s)$  in equilibrium with  $\text{BaO}(s)$  and  $\text{O}_2(g)$  as represented by the equation above. Which of the following changes will increase the amount of  $\text{BaO}_2(s)$  in the vessel?
- (A) Removing a small amount of  $\text{O}_2(g)$
  - (B) Removing a small amount of  $\text{BaO}(s)$
  - (C) Adding He gas to the vessel
  - (D) Lowering the temperature
5. Which of the following best helps to explain why the value of  $\Delta H^\circ$  for the dissolving of  $\text{CaF}_2$  in water is positive?
- (A)  $\text{CaF}_2(s)$  is insoluble in water.
  - (B)  $\text{CaF}_2(s)$  dissolves in water to form  $\text{CaF}_2(aq)$  particles.
  - (C)  $\text{Ca}^{2+}$  ions have very strong ion-ion interactions with  $\text{F}^-$  ions in the crystal lattice.
  - (D)  $\text{Ca}^{2+}$  ions have very strong ion-dipole interactions with water molecules in the solution.

6. Under which of the following conditions of temperature and pressure will  $\text{H}_2$  gas be expected to behave most like an ideal gas?

- (A) 50 K and 0.10 atm
- (B) 50 K and 5.0 atm
- (C) 500 K and 0.10 atm
- (D) 500 K and 50 atm

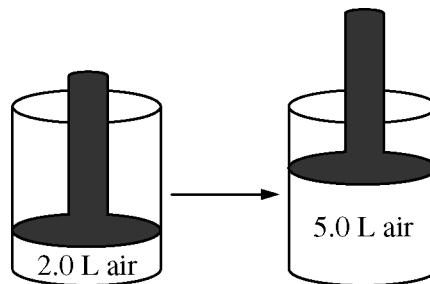

7. The volume of a sample of air in a cylinder with a movable piston is 2.0 L at a pressure  $P_1$ , as shown in the diagram above. The volume is increased to 5.0 L as the temperature is held constant. The pressure of the air in the cylinder is now  $P_2$ . What effect do the volume and pressure changes have on the average kinetic energy of the molecules in the sample?

- (A) The average kinetic energy increases.
- (B) The average kinetic energy decreases.
- (C) The average kinetic energy stays the same.
- (D) It cannot be determined how the kinetic energy is affected without knowing  $P_1$  and  $P_2$ .

**Questions 8-10 refer to the following.**

$M^+$  is an unknown metal cation with a +1 charge. A student dissolves the chloride of the unknown metal,  $MCl$ , in enough water to make 100.0 mL of solution. The student then mixes the solution with excess  $AgNO_3$  solution, causing  $AgCl$  to precipitate. The student collects the precipitate by filtration, dries it, and records the data shown below. (The molar mass of  $AgCl$  is 143 g/mol.)

Mass of unknown chloride, $MCl$	0.74 g
Mass of filter paper	0.80 g
Mass of filter paper plus $AgCl$ precipitate	2.23 g

8. What is the identity of the metal chloride?
- (A)  $NaCl$
  - (B)  $KCl$
  - (C)  $CuCl$
  - (D)  $LiCl$
9. During the course of the experiment, which of the following happens to the  $NO_3^-$  ions?
- (A) They are oxidized by  $Cl^-$  ions.
  - (B) They are reduced to  $NO_2^-$  ions.
  - (C) They are decomposed by reacting with  $M^+$  ions.
  - (D) They remain dissolved in the filtrate solution.

10. Which of the following diagrams best represents the  $\text{AgNO}_3$  solution before the reaction occurs?

Note: water molecules are represented by the symbol .

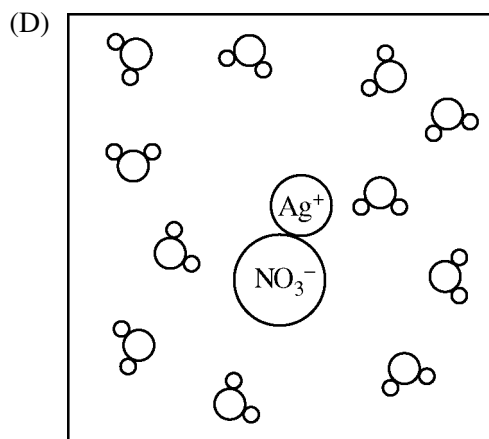
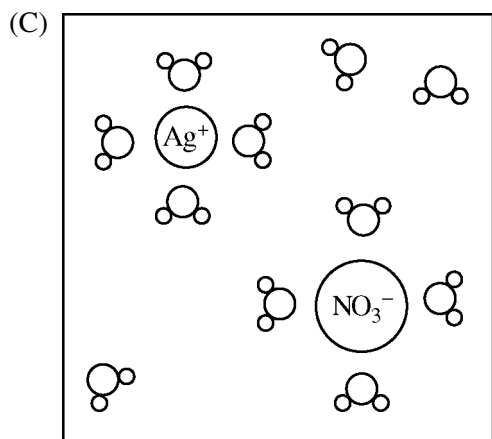
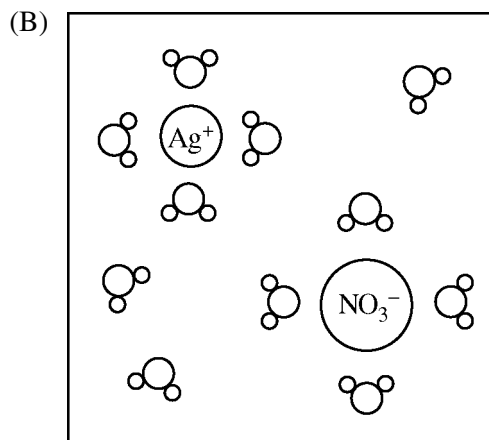
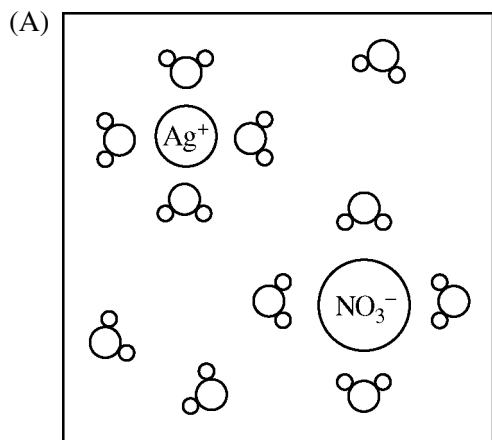

11. When 200. mL of 2.0 M NaOH(aq) is added to 500. mL of 1.0 M HCl(aq), the pH of the resulting mixture is closest to
- (A) 1.0  
(B) 3.0  
(C) 7.0  
(D) 13.0

13. Which of the following equations represents a reaction for which the standard entropy change is positive ( $\Delta S^\circ > 0$ ) ?
- (A)  $3 \text{O}_2(g) \rightarrow 2 \text{O}_3(g)$   
(B)  $2 \text{H}_2(g) + \text{O}_2(g) \rightarrow 2 \text{H}_2\text{O}(l)$   
(C)  $\text{CaCO}_3(s) \rightarrow \text{CaO}(s) + \text{CO}_2(g)$   
(D)  $\text{I}_2(g) + 2 \text{K}(s) \rightarrow 2 \text{KI}(s)$

---

Element	First Ionization Energy (kJ/mol)	Atomic Radius (pm)
B	801	85
C	1086	77
N	1400	75
O	1314	73
F	1680	72
Ne	2080	70

12. The table above shows the first ionization energy and atomic radius of several elements. Which of the following best helps to explain the deviation of the first ionization energy of oxygen from the overall trend?
- (A) The atomic radius of oxygen is greater than the atomic radius of fluorine.  
(B) The atomic radius of oxygen is less than the atomic radius of nitrogen.  
(C) There is repulsion between paired electrons in oxygen's 2p orbitals.  
(D) There is attraction between paired electrons in oxygen's 2p orbitals.



**Questions 14-16 refer to the following.**

The table below contains information about samples of four different gases at 273 K. The samples are in four identical rigid containers numbered 1 through 4.

Container	Gas	Pressure (atm)	Mass of Sample (g)
1	He	2.00	?
2	Ne	2.00	?
3	?	2.00	16.0
4	SO <sub>2</sub>	1.96	64.1

14. On the basis of the data provided above, the gas in container 3 could be
- (A) CH<sub>4</sub>
  - (B) O<sub>2</sub>
  - (C) Ar
  - (D) CO<sub>2</sub>
15. Under the conditions given, consider containers 1, 2, and 4 only. The average speed of the gas particles is
- (A) greatest in container 1
  - (B) greatest in container 2
  - (C) greatest in container 4
  - (D) the same in containers 1, 2, and 4
16. The best explanation for the lower pressure in container 4 is that SO<sub>2</sub> molecules
- (A) have a larger average speed than the other three gases
  - (B) occupy a larger portion of the container volume than the other three gases
  - (C) have stronger intermolecular attractions than the other three gases
  - (D) contain  $\pi$  bonds, while the other gases contain only  $\sigma$  bonds

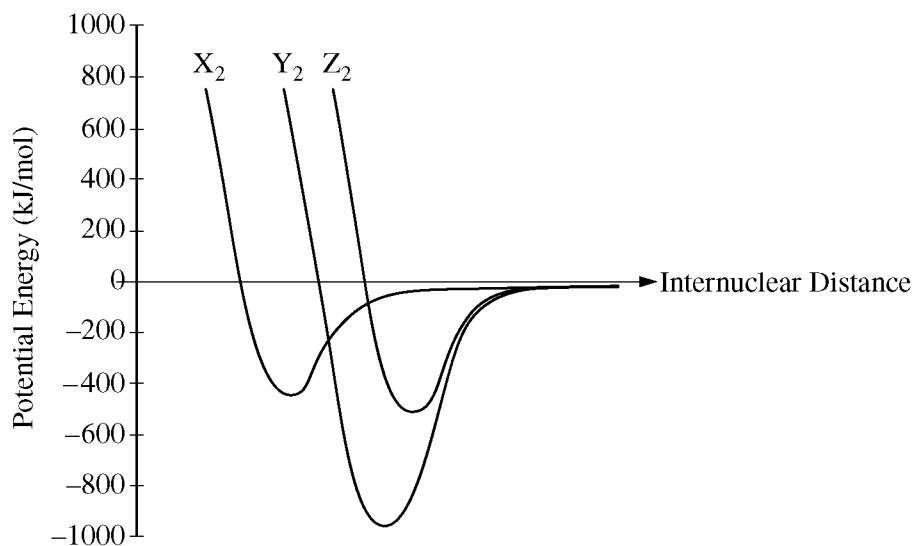

17. The potential energy as a function of internuclear distance for three diatomic molecules,  $X_2$ ,  $Y_2$ , and  $Z_2$ , is shown in the graph above. Based on the data in the graph, which of the following correctly identifies the diatomic molecules,  $X_2$ ,  $Y_2$ , and  $Z_2$ ?

	$X_2$	$Y_2$	$Z_2$
(A)	$H_2$	$N_2$	$O_2$
(B)	$H_2$	$O_2$	$N_2$
(C)	$N_2$	$O_2$	$H_2$
(D)	$O_2$	$H_2$	$N_2$

18. A 10. g cube of copper at a temperature  $T_1$  is placed in an insulated cup containing 10. g of water at a temperature  $T_2$ . If  $T_1 > T_2$ , which of the following is true of the system when it has attained thermal equilibrium? (The specific heat of copper is  $0.385 \text{ J}/(\text{g}\cdot^\circ\text{C})$  and the specific heat of water is  $4.18 \text{ J}/(\text{g}\cdot^\circ\text{C})$ .)

- (A) The temperature of the copper changed more than the temperature of the water.
- (B) The temperature of the water changed more than the temperature of the copper.
- (C) The temperature of the water and the copper changed by the same amount.
- (D) The relative temperature changes of the copper and the water cannot be determined without knowing  $T_1$  and  $T_2$ .

19. A solution containing HCl and the weak acid  $\text{HClO}_2$  has a pH of 2.4. Enough  $\text{KOH}(aq)$  is added to the solution to increase the pH to 10.5. The amount of which of the following species increases as the  $\text{KOH}(aq)$  is added?

- (A)  $\text{Cl}^-(aq)$
- (B)  $\text{H}^+(aq)$
- (C)  $\text{ClO}_2^-(aq)$
- (D)  $\text{HClO}_2(aq)$

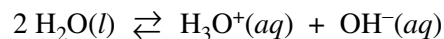

20. The autoionization of water is represented by the equation above. Values of  $\text{p}K_w$  at various temperatures are listed in the table below.

Temperature ( $^\circ\text{C}$ )	$\text{p}K_w$
0	14.9
10	14.5
20	14.2
30	13.8
40	13.5

Based on the information above, which of the following statements is true?

- (A) The dissociation of water is an exothermic process.
- (B) The pH of pure water is 7.00 at any temperature.
- (C) As the temperature increases, the pH of pure water increases.
- (D) As the temperature increases, the pH of pure water decreases.

**Questions 21-24 refer to the following information.**

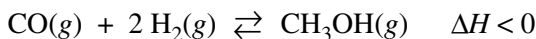

The synthesis of  $\text{CH}_3\text{OH}(g)$  from  $\text{CO}(g)$  and  $\text{H}_2(g)$  is represented by the equation above. The value of  $K_c$  for the reaction at 483 K is 14.5.

21. Which of the following explains the effect on the equilibrium constant,  $K_c$ , when the temperature of the reaction system is increased to 650 K?
- (A)  $K_c$  will increase because the activation energy of the forward reaction increases more than that of the reverse reaction.
  - (B)  $K_c$  will increase because there are more reactant molecules than product molecules.
  - (C)  $K_c$  will decrease because the reaction is exothermic.
  - (D)  $K_c$  is constant and will not change.
22. A 1.0 mol sample of  $\text{CO}(g)$  and a 1.0 mol sample of  $\text{H}_2(g)$  are pumped into a rigid, previously evacuated 2.0 L reaction vessel at 483 K. Which of the following is true at equilibrium?
- (A)  $[\text{H}_2] = 2[\text{CO}]$
  - (B)  $[\text{H}_2] < [\text{CO}]$
  - (C)  $[\text{CO}] = [\text{CH}_3\text{OH}] < [\text{H}_2]$
  - (D)  $[\text{CO}] = [\text{CH}_3\text{OH}] = [\text{H}_2]$
23. A mixture of  $\text{CO}(g)$  and  $\text{H}_2(g)$  is pumped into a previously evacuated 2.0 L reaction vessel. The total pressure of the reaction system is 1.2 atm at equilibrium. What will be the total pressure of the system if the volume of the reaction vessel is reduced to 1.0 L at constant temperature?
- (A) Less than 1.2 atm
  - (B) Greater than 1.2 atm but less than 2.4 atm
  - (C) 2.4 atm
  - (D) Greater than 2.4 atm
24. Which of the following statements is true about bond energies in this reaction?
- (A) The energy absorbed as the bonds in the reactants are broken is greater than the energy released as the bonds in the product are formed.
  - (B) The energy released as the bonds in the reactants are broken is greater than the energy absorbed as the bonds in the product are formed.
  - (C) The energy absorbed as the bonds in the reactants are broken is less than the energy released as the bonds in the product are formed.
  - (D) The energy released as the bonds in the reactants are broken is less than the energy absorbed as the bonds in the product are formed.

25. A solution is prepared by adding 100 mL of 1.0 M  $\text{HC}_2\text{H}_3\text{O}_2(aq)$  to 100 mL of 1.0 M  $\text{NaC}_2\text{H}_3\text{O}_2(aq)$ . The solution is stirred and its pH is measured to be 4.73. After 3 drops of 1.0 M HCl are added to the solution, the pH of the solution is measured and is still 4.73. Which of the following equations represents the chemical reaction that accounts for the fact that acid was added but there was no detectable change in pH?

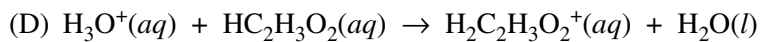
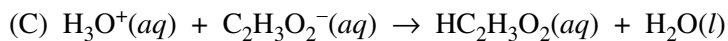
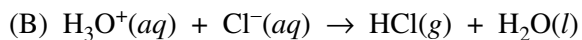

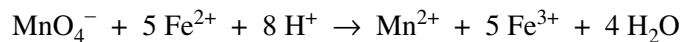

26. In the reaction represented above, the number of  $\text{MnO}_4^-$  ions that react must be equal to which of the following?
- (A) One-fifth the number of  $\text{Fe}^{2+}$  ions that are consumed
  - (B) Eight times the number of  $\text{H}^+$  ions that are consumed
  - (C) Five times the number of  $\text{Fe}^{3+}$  ions that are produced
  - (D) One-half the number of  $\text{H}_2\text{O}$  molecules that are produced

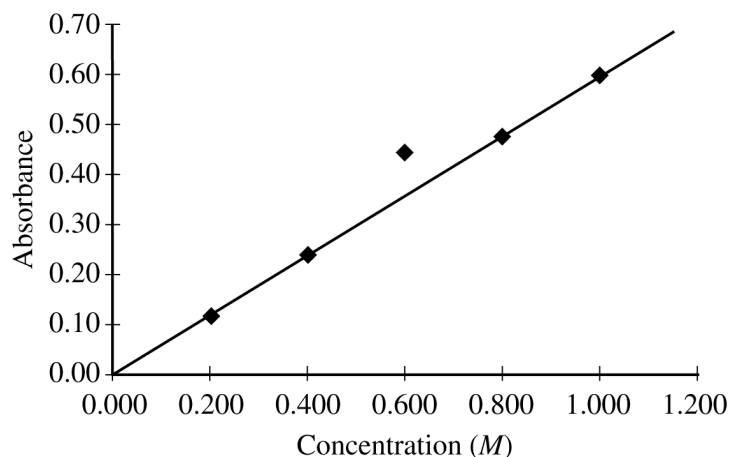

27. A student prepared five solutions of  $\text{CuSO}_4$  with different concentrations, and then filled five cuvettes, each containing one of the solutions. The cuvettes were placed in a spectrophotometer set to the appropriate wavelength for maximum absorbance. The absorbance of each solution was measured and recorded. The student plotted absorbance versus concentration, as shown in the figure above. Which of the following is the most likely explanation for the variance of the data point for the 0.600 M  $\text{CuSO}_4$  solution?
- (A) The cuvette into which the 0.600 M solution was placed had some water droplets inside.
  - (B) The cuvette into which the 0.600 M solution was placed was filled slightly more than the other cuvettes.
  - (C) The wavelength setting was accidentally moved away from that of maximum absorbance.
  - (D) The cuvette used for the 0.600 M solution had not been wiped clean before being put in the spectrophotometer.

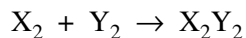

$$\text{rate} = k[X_2]$$

28. A reaction and its experimentally determined rate law are represented above. A chemist proposes two different possible mechanisms for the reaction, which are given below.

Mechanism 1

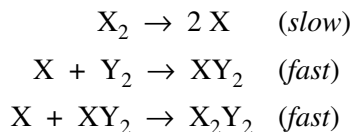

Mechanism 2

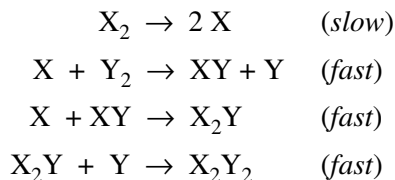

Based on the information above, which of the following is true?

- (A) Only mechanism 1 is consistent with the rate law.
- (B) Only mechanism 2 is consistent with the rate law.
- (C) Both mechanism 1 and mechanism 2 are consistent with the rate law.
- (D) Neither mechanism 1 nor mechanism 2 is consistent with the rate law.

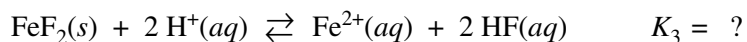
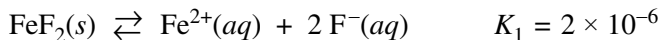

29. On the basis of the information above, the dissolution of  $FeF_2(s)$  in acidic solution is

- (A) thermodynamically favorable, because  $K_2 > 1$
- (B) thermodynamically favorable, because  $K_3 > 1$
- (C) not thermodynamically favorable, because  $K_1 < 1$
- (D) not thermodynamically favorable, because  $K_3 < 1$

30. Thymine and adenine form a base pair in the DNA molecule. These two bases can form a connection between two strands of DNA via two hydrogen bonds. Which of the following diagrams shows the correct representation of the hydrogen bonding (denoted by dashed lines) between thymine and adenine base pairs? (In each diagram, thymine is shown at the left and adenine is shown at the right. The bases are attached to the backbone portion of the DNA strands.)

(A)

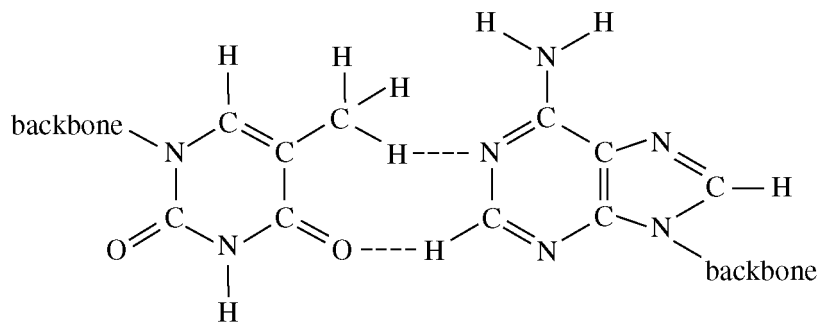

(B)

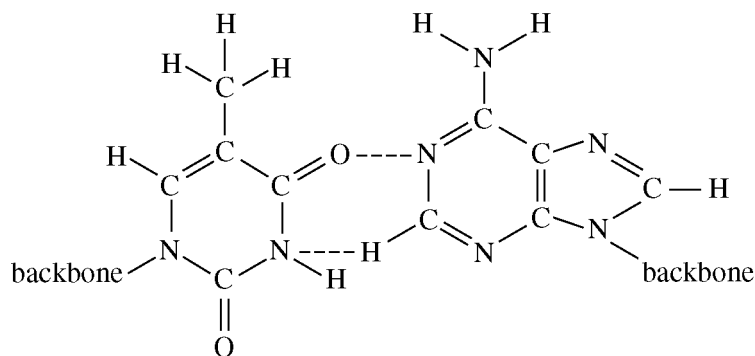

(C)

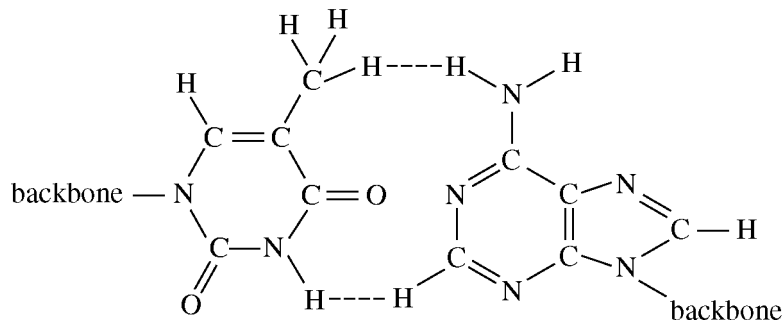

(D)

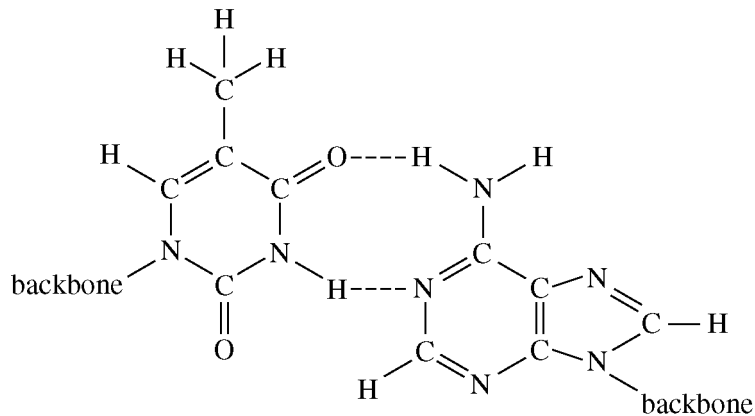



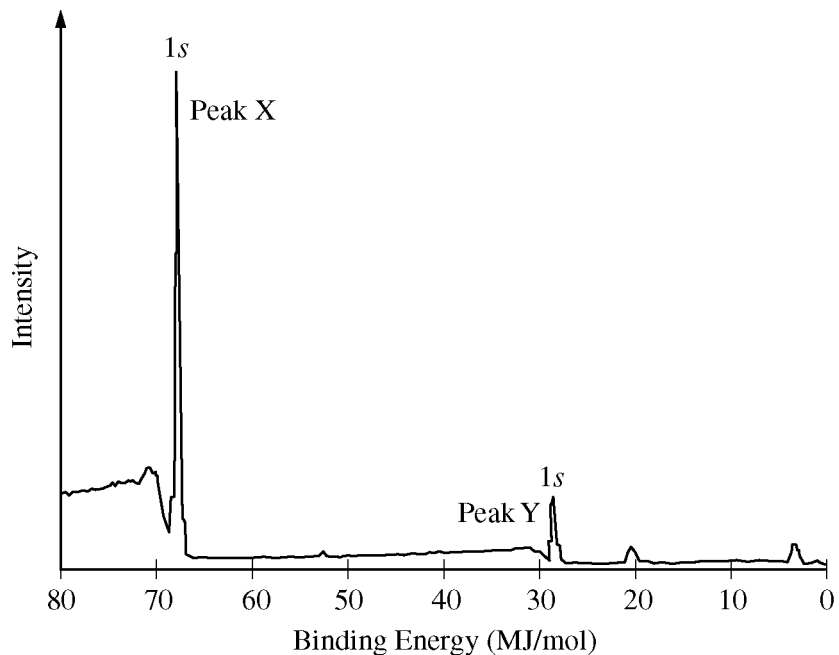

31. A sample containing atoms of C and F was analyzed using x-ray photoelectron spectroscopy. The portion of the spectrum showing the  $1s$  peaks for atoms of the two elements is shown above. Which of the following correctly identifies the  $1s$  peak for the F atoms and provides an appropriate explanation?
- (A) Peak X, because F has a smaller first ionization energy than C has.
  - (B) Peak X, because F has a greater nuclear charge than C has.
  - (C) Peak Y, because F is more electronegative than C is.
  - (D) Peak Y, because F has a smaller atomic radius than C has.

Questions 32-34 refer to the following.

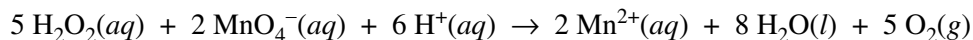

In a titration experiment,  $\text{H}_2\text{O}_2(aq)$  reacts with aqueous  $\text{MnO}_4^-(aq)$  as represented by the equation above. The dark purple  $\text{KMnO}_4$  solution is added from a buret to a colorless, acidified solution of  $\text{H}_2\text{O}_2(aq)$  in an Erlenmeyer flask. (Note: At the end point of the titration, the solution is a pale pink color.)

32. At a certain time during the titration, the rate of appearance of  $\text{O}_2(g)$  was  $1.0 \times 10^{-3} \text{ mol}/(\text{L}\cdot\text{s})$ . What was the rate of disappearance of  $\text{MnO}_4^-$  at the same time?
- (A)  $6.0 \times 10^{-3} \text{ mol}/(\text{L}\cdot\text{s})$   
(B)  $4.0 \times 10^{-3} \text{ mol}/(\text{L}\cdot\text{s})$   
(C)  $6.0 \times 10^{-4} \text{ mol}/(\text{L}\cdot\text{s})$   
(D)  $4.0 \times 10^{-4} \text{ mol}/(\text{L}\cdot\text{s})$
33. Which element is being oxidized during the titration, and what is the element's change in oxidation number?
- (A) Oxygen, which changes from  $-1$  to  $0$   
(B) Oxygen, which changes from  $0$  to  $-2$   
(C) Manganese, which changes from  $-1$  to  $+2$   
(D) Manganese, which changes from  $+7$  to  $+2$
34. Which of the following best describes what happens to the pH of the  $\text{H}_2\text{O}_2$  solution as the titration proceeds?
- (A) The  $+2$  charge on the manganese ions maintains the acidity of the solution.  
(B) The production of water dilutes the solution, making it basic.  
(C) As  $\text{H}^+$  ions are consumed, the solution becomes less acidic and the pH increases.  
(D) As  $\text{H}^+$  ions are consumed, the solution becomes less acidic and the pH decreases.

35. The  $\text{BF}_3$  molecule is nonpolar, whereas the  $\text{NF}_3$  molecule is polar. Which of the following statements accounts for the difference in polarity of the two molecules?

- (A) In  $\text{NF}_3$ , each F is joined to N with multiple bonds, whereas in  $\text{BF}_3$ , each F is joined to B with single bonds.
- (B) N – F bonds are polar, whereas B – F bonds are nonpolar.
- (C)  $\text{NF}_3$  is an ionic compound, whereas  $\text{BF}_3$  is a molecular compound.
- (D) Unlike  $\text{BF}_3$ ,  $\text{NF}_3$  has a nonplanar geometry due to an unshared pair of electrons on the N atom.

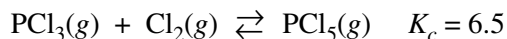

36. At a certain point in time, a 1.00 L rigid reaction vessel contains 1.5 mol of  $\text{PCl}_3(g)$ , 1.0 mol of  $\text{Cl}_2(g)$ , and 2.5 mol of  $\text{PCl}_5(g)$ . Which of the following describes how the measured pressure in the reaction vessel will change and why it will change that way as the reaction system approaches equilibrium at constant temperature?

- (A) The pressure will increase because  $Q < K_c$ .
- (B) The pressure will increase because  $Q > K_c$ .
- (C) The pressure will decrease because  $Q < K_c$ .
- (D) The pressure will decrease because  $Q > K_c$ .

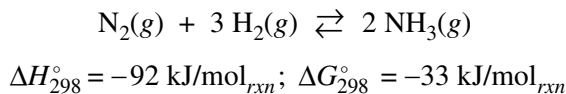

37. Consider the reaction represented above at 298 K. When equal volumes of  $\text{N}_2(g)$  and  $\text{H}_2(g)$ , each at 1 atm, are mixed in a closed container at 298 K, no formation of  $\text{NH}_3(g)$  is observed. Which of the following best explains the observation?

- (A) The  $\text{N}_2(g)$  and the  $\text{H}_2(g)$  must be mixed in a 1:3 ratio for a reaction to occur.
- (B) A high activation energy makes the forward reaction extremely slow at 298 K.
- (C) The reaction has an extremely small equilibrium constant, thus almost no product will form.
- (D) The reverse reaction has a lower activation energy than the forward reaction, so the forward reaction does not occur.

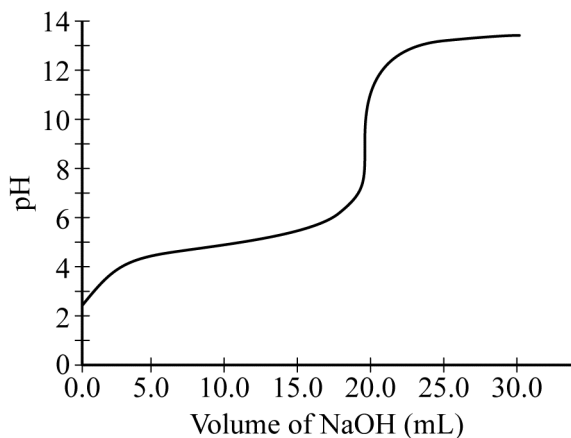

38. Data collected during the titration of a 20.0 mL sample of a 0.10 *M* solution of a monoprotic acid with a solution of NaOH of unknown concentration are plotted in the graph above. Based on the data, which of the following are the approximate  $pK_a$  of the acid and the molar concentration of the NaOH?

	$pK_a$	[NaOH]
(A)	4.7	0.050 <i>M</i>
(B)	4.7	0.10 <i>M</i>
(C)	9.3	0.050 <i>M</i>
(D)	9.3	0.10 <i>M</i>

Questions 39-41 refer to the following graph, which shows the heating curve for methane,  $\text{CH}_4$ .

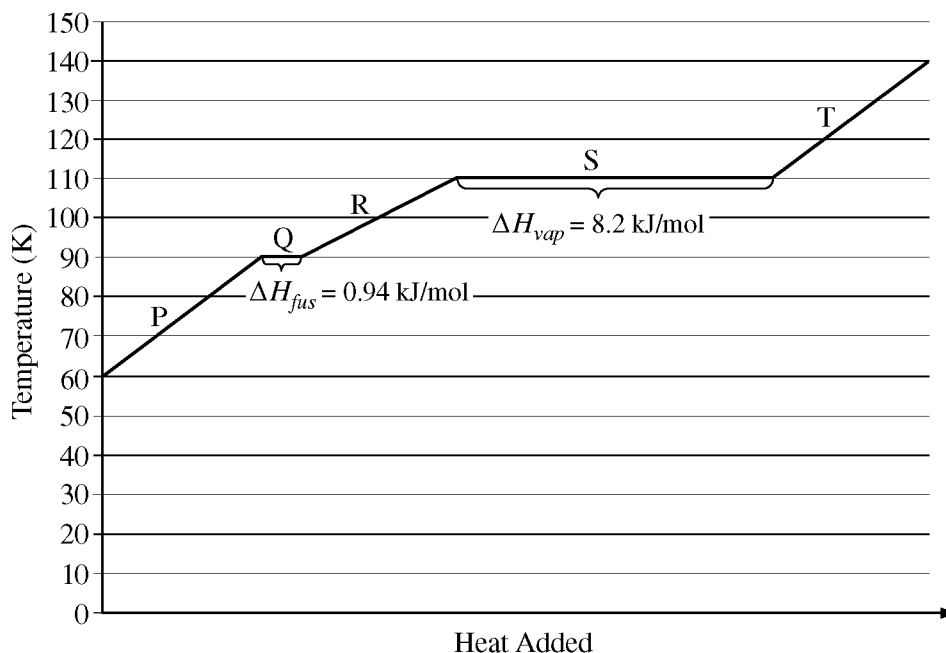

39. How much energy is required to melt 64 g of methane at 90 K? (The molar mass of methane is 16 g/mol.)
- (A) 0.24 kJ  
 (B) 3.8 kJ  
 (C) 33 kJ  
 (D) 60. kJ
40. Which of the following best explains why more energy is required for the process occurring at 110 K than for the process occurring at 90 K ?
- (A) Intermolecular attractions are completely overcome during vaporization.  
 (B) Intermolecular attractions in the solid phase are weaker than in the liquid phase.  
 (C) Electron clouds of methane molecules are less polarizable at lower temperatures.  
 (D) Vaporization involves a large increase in temperature.
41. The enthalpy of vaporization of water is 40.7 kJ/mol. Which of the following best explains why the enthalpy of vaporization of methane is less than that of water?
- (A) Methane does not exhibit hydrogen bonding, but water does.  
 (B) Methane has weaker dispersion forces.  
 (C) Methane has a smaller molar mass.  
 (D) Methane has a much lower density.

42. Steel is an alloy consisting of Fe with a small amount of C. Elemental Cr can be added to steel to make the steel less likely to rust; Cr atoms react with oxygen in the air to form a nonreactive layer of chromium oxide on the surface of the steel, preventing the oxidation of underlying Fe atoms. A sample of steel-chromium alloy contains 15 percent Cr by mass. Which of the following diagrams best shows a particle-level view of a surface section and an interior section of the alloy represented below at the left? (The atomic radii of the atoms involved are given in the table below at the right.)

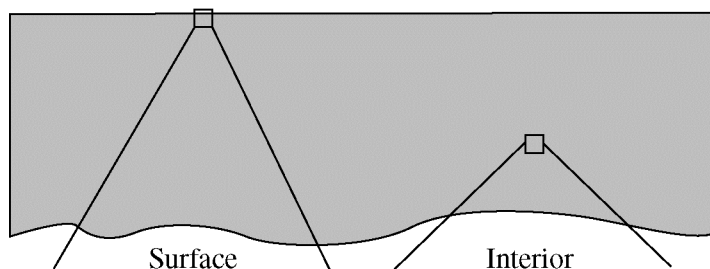

Element	Molar Mass (g/mol)	Atomic Radius (pm)
Fe	55.85	125
Cr	52.00	127
C	12.01	77
O	16.00	73

(A) (B) (C) (D)

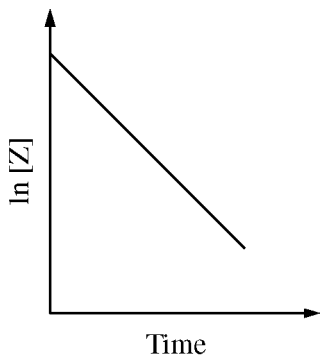

43. Consider the reaction represented by the equation  $2 X + 2 Z \rightarrow X_2Z_2$ . During a reaction in which a large excess of reactant  $X$  was present, the concentration of reactant  $Z$  was monitored over time. A plot of the natural logarithm of the concentration of  $Z$  versus time is shown in the figure above. The order of the reaction with respect to reactant  $Z$  is
- (A) zero order
  - (B) first order
  - (C) second order
  - (D) third order

Questions 44-46 relate to the following information.

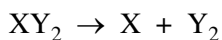

The equation above represents the decomposition of a compound  $\text{XY}_2$ . The diagram below shows two reaction profiles (path one and path two) for the decomposition of  $\text{XY}_2$ .

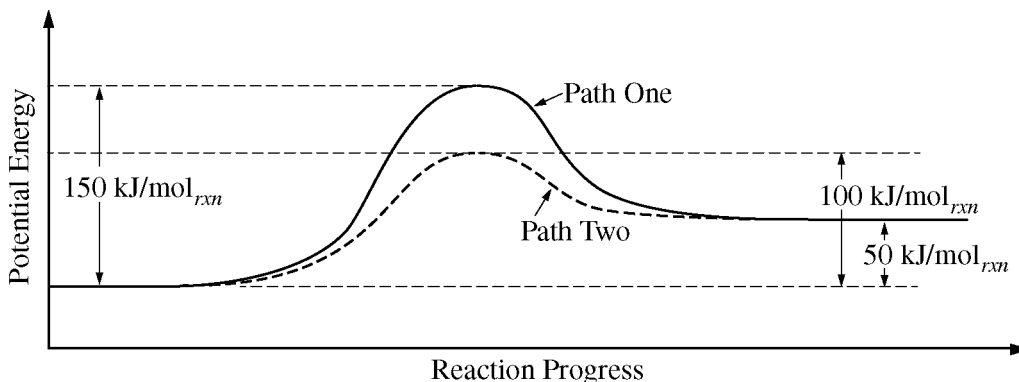

44. Which of the following most likely accounts for the difference between reaction path one and reaction path two?
- (A) A higher temperature in path one
  - (B) A higher temperature in path two
  - (C) The presence of a catalyst in path one
  - (D) The presence of a catalyst in path two
45. Which of the following best describes the flow of heat when 1.0 mol of  $\text{XY}_2$  decomposes?
- (A) 50 kJ of heat is transferred to the surroundings.
  - (B) 50 kJ of heat is transferred from the surroundings.
  - (C) 100 kJ of heat is transferred to the surroundings.
  - (D) 100 kJ of heat is transferred from the surroundings.
46. The reaction is thermodynamically favorable under standard conditions at 298 K. Therefore, the value of  $\Delta S^\circ$  for the reaction must be
- (A) equal to zero
  - (B) equal to  $\Delta H^\circ/298 \text{ K}$
  - (C) greater than  $\Delta H^\circ/298 \text{ K}$
  - (D) less than  $\Delta H^\circ/298 \text{ K}$



47. Which of the following diagrams best illustrates how a displacement in an ionic crystal results in cleavage and brittleness?

Before Displacement

After Displacement

(A)

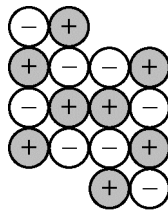
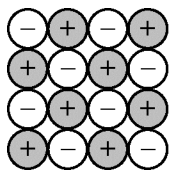

(B)

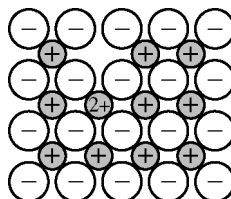
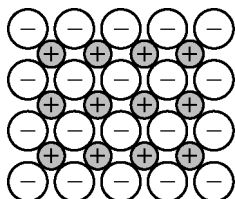

(C)

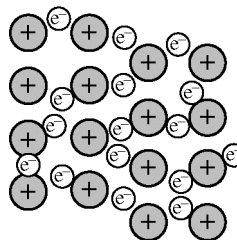
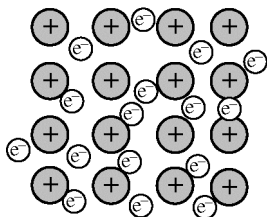

(D)

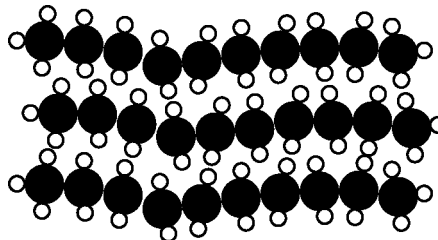
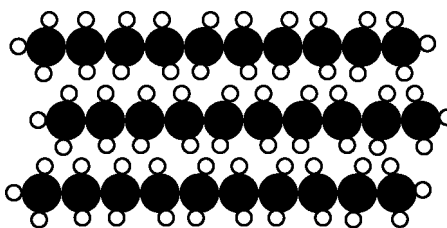

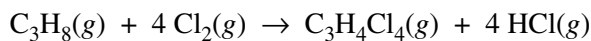

48. A 6.0 mol sample of  $\text{C}_3\text{H}_8(g)$  and a 20. mol sample of  $\text{Cl}_2(g)$  are placed in a previously evacuated vessel, where they react according to the equation above. After one of the reactants has been totally consumed, how many moles of  $\text{HCl}(g)$  have been produced?

- (A) 4.0 mol
- (B) 8.0 mol
- (C) 20. mol
- (D) 24 mol

Name	Structural Formula	Molar Mass (g/mol)
Acetone	$\begin{array}{c} \text{H} \quad \text{O} \quad \text{H} \\   \quad    \quad   \\ \text{H}-\text{C}-\text{C}-\text{C}-\text{H} \\   \quad \quad   \\ \text{H} \quad \quad \text{H} \end{array}$	58.1
1-propanol	$\begin{array}{c} \text{H} \quad \text{H} \quad \text{H} \\   \quad   \quad   \\ \text{H}-\text{C}-\text{C}-\text{C}-\text{O}-\text{H} \\   \quad   \quad   \\ \text{H} \quad \text{H} \quad \text{H} \end{array}$	60.1
Butane	$\begin{array}{c} \text{H} \quad \text{H} \quad \text{H} \quad \text{H} \\   \quad   \quad   \quad   \\ \text{H}-\text{C}-\text{C}-\text{C}-\text{C}-\text{H} \\   \quad   \quad   \quad   \\ \text{H} \quad \text{H} \quad \text{H} \quad \text{H} \end{array}$	58.1

49. The table above shows the structural formulas and molar masses for three different compounds. Which of the following is a list of the compounds in order of increasing boiling points?

- (A) Butane < 1-propanol < acetone
- (B) Butane < acetone < 1-propanol
- (C) 1-propanol < acetone < butane
- (D) Acetone = butane < 1-propanol

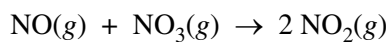

$$\text{rate} = k[\text{NO}][\text{NO}_3]$$

50. The reaction represented above occurs in a single step that involves the collision between a particle of NO and a particle of NO<sub>3</sub>. A scientist correctly calculates the rate of collisions between NO and NO<sub>3</sub> that have sufficient energy to overcome the activation energy. The observed reaction rate is only a small fraction of the calculated collision rate. Which of the following best explains the discrepancy?
- (A) The energy of collisions between two reactant particles is frequently absorbed by collision with a third particle.
  - (B) The two reactant particles must collide with a particular orientation in order to react.
  - (C) The activation energy for a reaction is dependent on the concentrations of the reactant particles.
  - (D) The activation energy for a reaction is dependent on the temperature.

# **S T O P**

**END OF SECTION I**

**IF YOU FINISH BEFORE TIME IS CALLED,  
YOU MAY CHECK YOUR WORK ON THIS SECTION.**

**DO NOT GO ON TO SECTION II UNTIL YOU ARE TOLD TO DO SO.**

---

**MAKE SURE YOU HAVE DONE THE FOLLOWING.**

- **PLACED YOUR AP NUMBER LABEL ON YOUR ANSWER SHEET**
- **WRITTEN AND GRIDDED YOUR AP NUMBER CORRECTLY ON YOUR ANSWER SHEET**
- **TAKEN THE AP EXAM LABEL FROM THE FRONT OF THIS BOOKLET AND PLACED IT ON YOUR ANSWER SHEET.**

---

## **Section II: Free-Response Questions**

This is the free-response section of the 2014 AP exam.  
It includes cover material and other administrative instructions  
to help familiarize students with the mechanics of the exam.  
(Note that future exams may differ in look from the following content.)

# AP<sup>®</sup> Chemistry Exam

## SECTION II: Free Response

2014

DO NOT OPEN THIS BOOKLET UNTIL YOU ARE TOLD TO DO SO.

### At a Glance

**Total Time**

1 hour, 30 minutes

**Number of Questions**

7

**Percent of Total Score**

50%

**Writing Instrument**

Either pencil or pen with black or dark blue ink

**Electronic Device**

Calculator allowed

**Suggested Time**

Approximately  
20 minutes each for  
questions 1–3 and  
7 minutes each for  
questions 4–7

**Weight**

Approximate weights:  
Questions 1–3  
22% each  
Questions 4–7  
9% each

### IMPORTANT Identification Information

PLEASE PRINT WITH PEN:

1. First two letters of your last name   
First letter of your first name
2. Date of birth  
    
Month Day Year
3. Six-digit school code
4. Unless I check the box below, I grant the College Board the unlimited right to use, reproduce, and publish my free-response materials, both written and oral, for educational research and instructional purposes. My name and the name of my school will not be used in any way in connection with my free-response materials. I understand that I am free to mark "No" with no effect on my score or its reporting.  
No, I do not grant the College Board  these rights.

### Instructions

The questions for Section II are printed in this booklet. Pages containing a periodic table and lists containing equations and constants are also printed in this booklet.

You may use the pages that the questions are printed on to organize your answers or for scratch work, but you must write your answers in the areas designated for each response. Only material written in the space provided will be scored.

Examples and equations may be included in your responses where appropriate. For calculations, clearly show the method used and the steps involved in arriving at your answers. You must show your work to receive credit for your answer. Pay attention to significant figures.

Write clearly and legibly. Cross out any errors you make; erased or crossed-out work will not be scored.

Manage your time carefully. You may proceed freely from one question to the next. You may review your responses if you finish before the end of the exam is announced.

DO NOT DETACH FROM BOOK.

## PERIODIC TABLE OF THE ELEMENTS

1	<b>H</b>											2	<b>He</b>										
	1.008												4.00										
3		4											9										
	<b>Li</b>	<b>Be</b>											<b>F</b>	<b>Ne</b>									
	6.94	9.01											19.00	20.18									
11		12											17	18									
	<b>Na</b>	<b>Mg</b>											<b>Cl</b>	<b>Ar</b>									
	22.99	24.30											35.45	39.95									
19		20	21	22	23	24	25	26	27	28	29	30	31	32	33	34	35	36					
	<b>K</b>	<b>Ca</b>	<b>Sc</b>	<b>Ti</b>	<b>V</b>	<b>Cr</b>	<b>Mn</b>	<b>Fe</b>	<b>Co</b>	<b>Ni</b>	<b>Cu</b>	<b>Zn</b>	<b>Ga</b>	<b>Ge</b>	<b>As</b>	<b>Se</b>	<b>Br</b>	<b>Kr</b>					
	39.10	40.08	44.96	47.90	50.94	52.00	54.94	55.85	58.93	58.69	63.55	65.39	69.72	72.59	74.92	78.96	79.90	83.80					
37		38	39	40	41	42	43	44	45	46	47	48	49	50	51	52	53	54					
	<b>Rb</b>	<b>Sr</b>	<b>Y</b>	<b>Zr</b>	<b>Nb</b>	<b>Mo</b>	<b>Tc</b>	<b>Ru</b>	<b>Rh</b>	<b>Pd</b>	<b>Ag</b>	<b>Cd</b>	<b>In</b>	<b>Sn</b>	<b>Sb</b>	<b>Te</b>	<b>I</b>	<b>Xe</b>					
	85.47	87.62	88.91	91.22	92.91	95.94	(98)	101.1	102.91	106.42	107.87	112.41	114.82	118.71	121.75	127.60	126.91	131.29					
55		56	57	72	73	74	75	76	77	78	79	80	81	82	83	84	85	86					
	<b>Cs</b>	<b>Ba</b>	<b>*La</b>	<b>Hf</b>	<b>Ta</b>	<b>W</b>	<b>Re</b>	<b>Os</b>	<b>Ir</b>	<b>Pt</b>	<b>Au</b>	<b>Hg</b>	<b>Tl</b>	<b>Pb</b>	<b>Bi</b>	<b>Po</b>	<b>At</b>	<b>Rn</b>					
	132.91	137.33	138.91	178.49	180.95	183.85	186.21	190.2	192.2	195.08	196.97	200.59	204.38	207.2	208.98	(209)	(210)	(222)					
87		88	89	104	105	106	107	108	109	110	111												
	<b>Fr</b>	<b>Ra</b>	<b>†Ac</b>	<b>Rf</b>	<b>Db</b>	<b>Sg</b>	<b>Bh</b>	<b>Hs</b>	<b>Mt</b>	<b>Ds</b>	<b>Rg</b>												
	(223)	226.02	227.03	(261)	(262)	(266)	(264)	(277)	(268)	(271)	(272)												
													66	67	68	69	70	71					
													<b>Dy</b>	<b>Ho</b>	<b>Er</b>	<b>Tm</b>	<b>Yb</b>	<b>Lu</b>					
													162.50	164.93	167.26	168.93	173.04	174.97					
													98	99	100	101	102	103					
													<b>Cf</b>	<b>Es</b>	<b>Fm</b>	<b>Md</b>	<b>No</b>	<b>Lr</b>					
													(251)	(252)	(257)	(258)	(259)	(262)					
													65	64	63	62	61	60	59	58			
													<b>Tb</b>	<b>Gd</b>	<b>Eu</b>	<b>Sm</b>	<b>Pm</b>	<b>Nd</b>	<b>Pr</b>	<b>Ce</b>			
													158.93	157.25	151.97	150.4	(145)	144.24	140.91	140.12			
													97	96	95	94	93	92	91	90			
													<b>Bk</b>	<b>Cm</b>	<b>Am</b>	<b>Pu</b>	<b>Np</b>	<b>U</b>	<b>Pa</b>	<b>Th</b>			
													(247)	(247)	(243)	(244)	(237)	238.03	231.04	232.04			
													*Lanthanide Series			†Actinide Series							

# AP<sup>®</sup> CHEMISTRY EQUATIONS AND CONSTANTS

Throughout the exam the following symbols have the definitions specified unless otherwise noted.

L, mL = liter(s), milliliter(s)

g = gram(s)

nm = nanometer(s)

atm = atmosphere(s)

mm Hg = millimeters of mercury

J, kJ = joule(s), kilojoule(s)

V = volt(s)

mol = mole(s)

## ATOMIC STRUCTURE

$$E = h\nu$$

$$c = \lambda\nu$$

$E$  = energy

$\nu$  = frequency

$\lambda$  = wavelength

Planck's constant,  $h = 6.626 \times 10^{-34}$  J s

Speed of light,  $c = 2.998 \times 10^8$  m s<sup>-1</sup>

Avogadro's number =  $6.022 \times 10^{23}$  mol<sup>-1</sup>

Electron charge,  $e = -1.602 \times 10^{-19}$  coulomb

## EQUILIBRIUM

$$K_c = \frac{[C]^c [D]^d}{[A]^a [B]^b}, \text{ where } a A + b B \rightleftharpoons c C + d D$$

$$K_p = \frac{(P_C)^c (P_D)^d}{(P_A)^a (P_B)^b}$$

$$K_a = \frac{[H^+][A^-]}{[HA]}$$

$$K_b = \frac{[OH^-][HB^+]}{[B]}$$

$$K_w = [H^+][OH^-] = 1.0 \times 10^{-14} \text{ at } 25^\circ\text{C}$$

$$= K_a \times K_b$$

$$\text{pH} = -\log [H^+], \text{ pOH} = -\log [OH^-]$$

$$14 = \text{pH} + \text{pOH}$$

$$\text{pH} = \text{p}K_a + \log \frac{[A^-]}{[HA]}$$

$$\text{p}K_a = -\log K_a, \text{ p}K_b = -\log K_b$$

### Equilibrium Constants

$K_c$  (molar concentrations)

$K_p$  (gas pressures)

$K_a$  (weak acid)

$K_b$  (weak base)

$K_w$  (water)

## KINETICS

$$\ln[A]_t - \ln[A]_0 = -kt$$

$$\frac{1}{[A]_t} - \frac{1}{[A]_0} = kt$$

$$t_{1/2} = \frac{0.693}{k}$$

$k$  = rate constant

$t$  = time

$t_{1/2}$  = half-life



## GASES, LIQUIDS, AND SOLUTIONS

$$PV = nRT$$

$$P_A = P_{\text{total}} \times X_A, \text{ where } X_A = \frac{\text{moles A}}{\text{total moles}}$$

$$P_{\text{total}} = P_A + P_B + P_C + \dots$$

$$n = \frac{m}{M}$$

$$K = ^\circ\text{C} + 273$$

$$D = \frac{m}{V}$$

$$KE \text{ per molecule} = \frac{1}{2}mv^2$$

Molarity,  $M$  = moles of solute per liter of solution

$$A = abc$$

$P$  = pressure

$V$  = volume

$T$  = temperature

$n$  = number of moles

$m$  = mass

$M$  = molar mass

$D$  = density

$KE$  = kinetic energy

$v$  = velocity

$A$  = absorbance

$a$  = molar absorptivity

$b$  = path length

$c$  = concentration

Gas constant,  $R$  =  $8.314 \text{ J mol}^{-1} \text{ K}^{-1}$

$$= 0.08206 \text{ L atm mol}^{-1} \text{ K}^{-1}$$

$$= 62.36 \text{ L torr mol}^{-1} \text{ K}^{-1}$$

$$1 \text{ atm} = 760 \text{ mm Hg} = 760 \text{ torr}$$

$$\text{STP} = 273.15 \text{ K and } 1.0 \text{ atm}$$

## THERMODYNAMICS / ELECTROCHEMISTRY

$$q = mc\Delta T$$

$$\Delta S^\circ = \sum S^\circ \text{ products} - \sum S^\circ \text{ reactants}$$

$$\Delta H^\circ = \sum \Delta H_f^\circ \text{ products} - \sum \Delta H_f^\circ \text{ reactants}$$

$$\Delta G^\circ = \sum \Delta G_f^\circ \text{ products} - \sum \Delta G_f^\circ \text{ reactants}$$

$$\Delta G^\circ = \Delta H^\circ - T\Delta S^\circ$$

$$= -RT \ln K$$

$$= -nFE^\circ$$

$$I = \frac{q}{t}$$

$q$  = heat

$m$  = mass

$c$  = specific heat capacity

$T$  = temperature

$S^\circ$  = standard entropy

$H^\circ$  = standard enthalpy

$G^\circ$  = standard Gibbs free energy

$n$  = number of moles

$E^\circ$  = standard reduction potential

$I$  = current (amperes)

$q$  = charge (coulombs)

$t$  = time (seconds)

Faraday's constant,  $F$  = 96,485 coulombs per mole of electrons

$$1 \text{ volt} = \frac{1 \text{ joule}}{1 \text{ coulomb}}$$

SECTION II BEGINS ON PAGE 6.

**GO ON TO THE NEXT PAGE.**

**CHEMISTRY**  
**Section II**  
**7 Questions**  
**Time—90 minutes**

**YOU MAY USE YOUR CALCULATOR FOR THIS SECTION.**

**Directions:** Questions 1–3 are long free-response questions that require about 20 minutes each to answer and are worth 10 points each. Questions 4–7 are short free-response questions that require about 7 minutes each to answer and are worth 4 points each.

Write your response in the space provided following each question. Examples and equations may be included in your responses where appropriate. For calculations, clearly show the method used and the steps involved in arriving at your answers. You must show your work to receive credit for your answer. Pay attention to significant figures.

Mass of KI tablet	0.425 g
Mass of thoroughly dried filter paper	1.462 g
Mass of filter paper + precipitate after first drying	1.775 g
Mass of filter paper + precipitate after second drying	1.699 g
Mass of filter paper + precipitate after third drying	1.698 g

1. A student is given the task of determining the  $I^-$  content of tablets that contain KI and an inert, water-soluble sugar as a filler. A tablet is dissolved in 50.0 mL of distilled water, and an excess of 0.20 M  $Pb(NO_3)_2(aq)$  is added to the solution. A yellow precipitate forms, which is then filtered, washed, and dried. The data from the experiment are shown in the table above.
  - (a) For the chemical reaction that occurs when the precipitate forms,
    - (i) write a balanced, net-ionic equation for the reaction, and
    - (ii) explain why the reaction is best represented by a net-ionic equation.
  - (b) Explain the purpose of drying and weighing the filter paper with the precipitate three times.
  - (c) In the filtrate solution, is  $[K^+]$  greater than, less than, or equal to  $[NO_3^-]$ ? Justify your answer.
  - (d) Calculate the number of moles of precipitate that is produced in the experiment.
  - (e) Calculate the mass percent of  $I^-$  in the tablet.
  - (f) In another trial, the student dissolves a tablet in 55.0 mL of water instead of 50.0 mL of water. Predict whether the experimentally determined mass percent of  $I^-$  will be greater than, less than, or equal to the amount calculated in part (e). Justify your answer.

















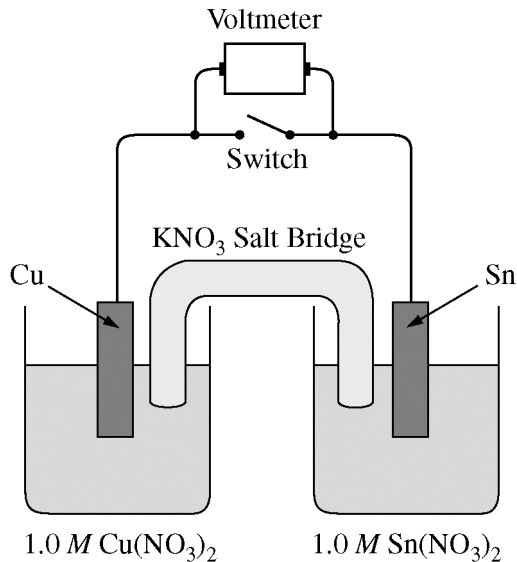

3. A student is given a standard galvanic cell, represented above, that has a Cu electrode and a Sn electrode. As current flows through the cell, the student determines that the Cu electrode increases in mass and the Sn electrode decreases in mass.
- Identify the electrode at which oxidation is occurring. Explain your reasoning based on the student's observations.
  - As the mass of the Sn electrode decreases, where does the mass go?
  - In the expanded view of the center portion of the salt bridge shown in the diagram below, draw and label a particle view of what occurs in the salt bridge as the cell begins to operate. Omit solvent molecules and use arrows to show the movement of particles.

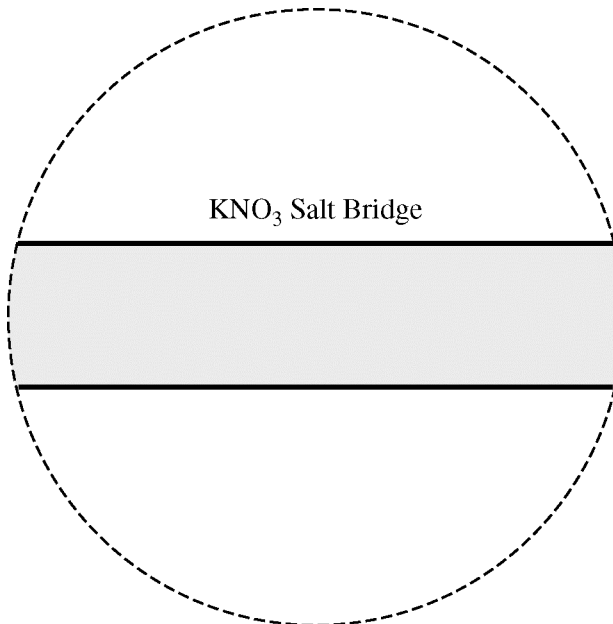









4. When heated, calcium carbonate decomposes according to the equation above. In a study of the decomposition of calcium carbonate, a student added a 50.0 g sample of powdered  $\text{CaCO}_3(s)$  to a 1.00 L rigid container. The student sealed the container, pumped out all the gases, then heated the container in an oven at 1100 K. As the container was heated, the total pressure of the  $\text{CO}_2(g)$  in the container was measured over time. The data are plotted in the graph below.

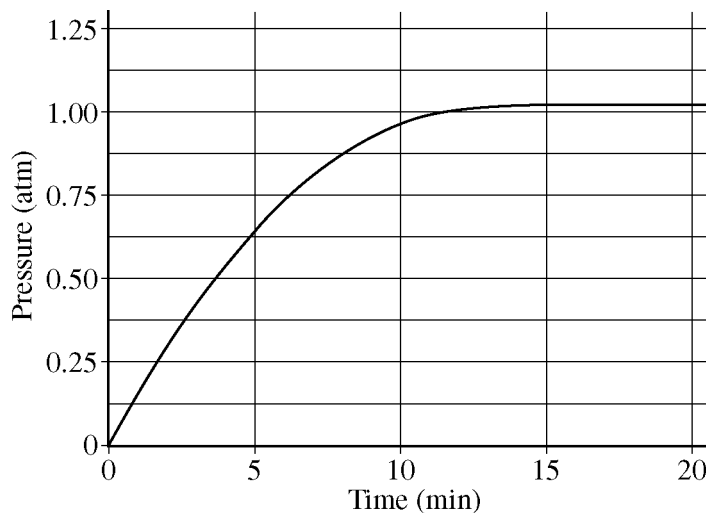

The student repeated the experiment, but this time the student used a 100.0 g sample of powdered  $\text{CaCO}_3(s)$ . In this experiment, the final pressure in the container was 1.04 atm, which was the same final pressure as in the first experiment.

- Calculate the number of moles of  $\text{CO}_2(g)$  present in the container after 20 minutes of heating.
- The student claimed that the final pressure in the container in each experiment became constant because all of the  $\text{CaCO}_3(s)$  had decomposed. Based on the data in the experiments, do you agree with this claim? Explain.
- After 20 minutes some  $\text{CO}_2(g)$  was injected into the container, initially raising the pressure to 1.5 atm. Would the final pressure inside the container be less than, greater than, or equal to 1.04 atm? Explain your reasoning.
- Are there sufficient data obtained in the experiments to determine the value of the equilibrium constant,  $K_p$ , for the decomposition of  $\text{CaCO}_3(s)$  at 1100 K? Justify your answer.

---

---

---

---

---





Nonmetal	C	N	O	Ne	Si	P	S	Ar
Formula of Compound	CF <sub>4</sub>	NF <sub>3</sub>	OF <sub>2</sub>	No compound	SiF <sub>4</sub>	PF <sub>3</sub>	SF <sub>2</sub>	No compound

5. Some binary compounds that form between fluorine and various nonmetals are listed in the table above. A student examines the data in the table and poses the following hypothesis: the number of F atoms that will bond to a nonmetal is always equal to 8 minus the number of valence electrons in the nonmetal atom.
- (a) Based on the student's hypothesis, what should be the formula of the compound that forms between chlorine and fluorine?
- (b) In an attempt to verify the hypothesis, the student researches the fluoride compounds of the other halogens and finds the formula ClF<sub>3</sub>. In the box below, draw a complete Lewis electron-dot diagram for a molecule of ClF<sub>3</sub>.

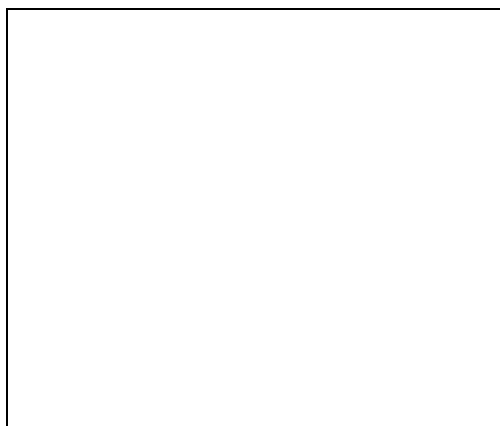

- (c) Two possible geometric shapes for the ClF<sub>3</sub> molecule are trigonal planar and T-shaped. The student does some research and learns that the molecule has a dipole moment. Which of the two shapes is consistent with the fact that the ClF<sub>3</sub> molecule has a dipole moment? Justify your answer in terms of bond polarity and molecular structure.

In an attempt to resolve the existence of the ClF<sub>3</sub> molecule with the hypothesis stated above, the student researches the compounds that form between halogens and fluorine, and assembles the following list.

Halogen	Formula(s)
F	F <sub>2</sub>
Cl	
Br	BrF, BrF <sub>3</sub> , BrF <sub>5</sub>
I	IF, IF <sub>3</sub> , IF <sub>5</sub> , IF <sub>7</sub>

- (d) Based on concepts of atomic structure and periodicity, propose a modification to the student's previous hypothesis to account for the compounds that form between halogens and fluorine.



6. A student places a mixture of plastic beads consisting of polypropylene (PP) and polyvinyl chloride (PVC) in a 1.0 L beaker containing distilled water. After stirring the contents of the beaker vigorously, the student observes that the beads of one type of plastic sink to the bottom of the beaker and the beads of the other type of plastic float on the water. The chemical structures of PP and PVC are represented by the diagrams below, which show segments of each polymer.

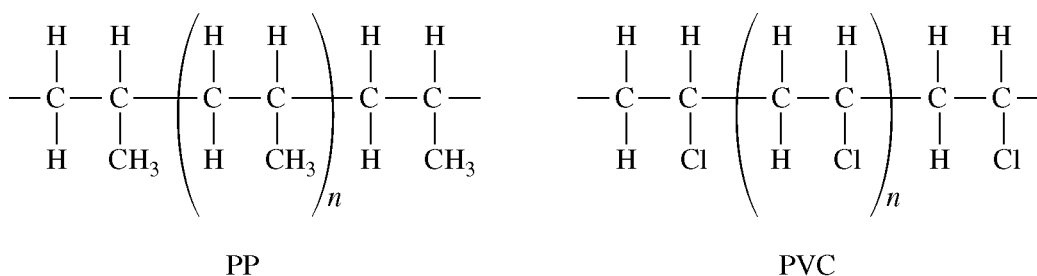

- (a) Given that the spacing between polymer chains in PP and PVC is similar, the beads that sink are made of which polymer? Explain.

PP is synthesized from propene,  $C_3H_6$ , and PVC is synthesized from vinyl chloride,  $C_2H_3Cl$ . The structures of the molecules are shown below.

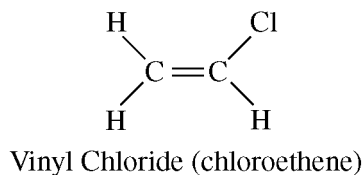
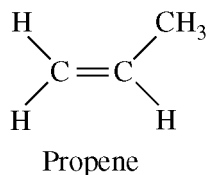

- (b) The boiling point of liquid propene (226 K) is lower than the boiling point of liquid vinyl chloride (260 K). Account for this difference in terms of the types and strengths of intermolecular forces present in each liquid.

In a separate experiment, the student measures the enthalpies of combustion of propene and vinyl chloride. The student determines that the combustion of 2.00 mol of vinyl chloride releases 2300 kJ of energy, according to the equation below.

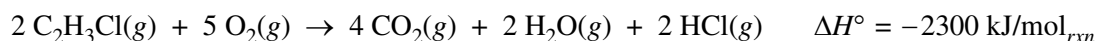

- (c) Using the table of standard enthalpies of formation below, determine whether the combustion of 2.00 mol of propene releases more, less, or the same amount of energy that 2.00 mol of vinyl chloride releases. Justify your answer with a calculation. The balanced equation for the combustion of 2.00 mol of propene is  $2 C_3H_6(g) + 9 O_2(g) \rightarrow 6 CO_2(g) + 6 H_2O(g)$ .

Substance	$C_2H_3Cl(g)$	$C_3H_6(g)$	$CO_2(g)$	$H_2O(g)$	$HCl(g)$	$O_2(g)$
Standard Enthalpy of Formation (kJ/mol)	37	21	-394	-242	-92	0







# **S T O P**

**END OF EXAM**

**IF YOU FINISH BEFORE TIME IS CALLED,  
YOU MAY CHECK YOUR WORK ON THIS SECTION.**

---

**THE FOLLOWING INSTRUCTIONS APPLY TO THE COVERS OF THE  
SECTION II BOOKLET.**

- **MAKE SURE YOU HAVE COMPLETED THE IDENTIFICATION INFORMATION AS REQUESTED ON THE FRONT AND BACK COVERS OF THE SECTION II BOOKLET.**
- **CHECK TO SEE THAT YOUR AP NUMBER LABEL APPEARS IN THE BOX ON THE FRONT COVER.**
- **MAKE SURE YOU HAVE USED THE SAME SET OF AP NUMBER LABELS ON ALL AP EXAMS YOU HAVE TAKEN THIS YEAR.**

---

## Multiple-Choice Answer Key

The following contains the answers to the multiple-choice questions in this exam.



## **Answer Key for AP Chemistry Practice Exam**

Question 1: B	Question 26: A
Question 2: B	Question 27: D
Question 3: D	Question 28: C
Question 4: D	Question 29: B
Question 5: C	Question 30: D
Question 6: C	Question 31: B
Question 7: C	Question 32: D
Question 8: B	Question 33: A
Question 9: D	Question 34: C
Question 10: A	Question 35: D
Question 11: A	Question 36: C
Question 12: C	Question 37: B
Question 13: C	Question 38: B
Question 14: A	Question 39: B
Question 15: A	Question 40: A
Question 16: C	Question 41: A
Question 17: A	Question 42: B
Question 18: A	Question 43: B
Question 19: C	Question 44: D
Question 20: D	Question 45: B
Question 21: C	Question 46: C
Question 22: B	Question 47: A
Question 23: B	Question 48: C
Question 24: C	Question 49: B
Question 25: C	Question 50: B

---

## Free-Response Scoring Guidelines

The following contains the scoring guidelines for the free-response questions in this exam.

**AP<sup>®</sup> CHEMISTRY**  
**2014 SCORING GUIDELINES**

**Question 1**  
**(10 points)**

Mass of KI tablet	0.425 g
Mass of thoroughly dried filter paper	1.462 g
Mass of filter paper + precipitate after first drying	1.775 g
Mass of filter paper + precipitate after second drying	1.699 g
Mass of filter paper + precipitate after third drying	1.698 g

A student is given the task of determining the  $I^-$  content of tablets that contain KI and an inert, water-soluble sugar as a filler. A tablet is dissolved in 50.0 mL of distilled water, and an excess of 0.20 M  $Pb(NO_3)_2(aq)$  is added to the solution. A yellow precipitate forms, which is then filtered, washed, and dried. The data from the experiment are shown in the table above.

- (a) For the chemical reaction that occurs when the precipitate forms,  
(i) write a balanced, net-ionic equation for the reaction, and

$Pb^{2+} + 2 I^- \rightarrow PbI_2$	1 point is earned for a balanced net-ionic equation.
-------------------------------------	--

- (ii) explain why the reaction is best represented by a net-ionic equation.

The net-ionic equation shows the formation of the $PbI_2(s)$ from $Pb^{2+}(aq)$ and $I^-(aq)$ ions, omitting the non-reacting species (spectator ions), $K^+(aq)$ and $NO_3^-(aq)$ .	1 point is earned for a valid explanation.
--	--

- (b) Explain the purpose of drying and weighing the filter paper with the precipitate three times.

The filter paper and precipitate must be dried several times (to a constant mass) to ensure that all the water has been driven off.	1 point is earned for a valid explanation.
---	--

- (c) In the filtrate solution, is  $[K^+]$  greater than, less than, or equal to  $[NO_3^-]$ ? Justify your answer.

$[K^+]$ is less than $[NO_3^-]$ because the source of the $NO_3^-$ , the 0.20 M $Pb(NO_3)_2(aq)$ , was added in excess.	1 point is earned for a correct comparison with a valid explanation.
---	--

**AP<sup>®</sup> CHEMISTRY**  
**2014 SCORING GUIDELINES**

**Question 1 (continued)**

(d) Calculate the number of moles of precipitate that is produced in the experiment.

$1.698 \text{ g} - 1.462 \text{ g} = 0.236 \text{ g PbI}_2(s)$ $0.236 \text{ g PbI}_2 \times \frac{1 \text{ mol PbI}_2}{461.0 \text{ g PbI}_2} = 5.12 \times 10^{-4} \text{ mol PbI}_2$	1 point is earned for the correct number of moles of $\text{PbI}_2(s)$ precipitate.
---	---

(e) Calculate the mass percent of  $\text{I}^-$  in the tablet.

$5.12 \times 10^{-4} \text{ mol PbI}_2 \times \frac{2 \text{ mol I}^-}{1 \text{ mol PbI}_2} = 1.02 \times 10^{-3} \text{ mol I}^-$ $1.02 \times 10^{-3} \text{ mol I}^- \times \frac{126.91 \text{ g I}^-}{1 \text{ mol I}^-} = 0.130 \text{ g I}^- \text{ in one tablet}$ $\frac{0.130 \text{ g I}^-}{0.425 \text{ g KI tablet}} = 0.306 = 30.6\% \text{ I}^- \text{ per KI tablet}$	1 point is earned for determining the number of moles of $\text{I}^-$ in one tablet.  1 point is earned for calculating the mass percent of $\text{I}^-$ in the KI tablet.
---	--

(f) In another trial, the student dissolves a tablet in 55.0 mL of water instead of 50.0 mL of water. Predict whether the experimentally determined mass percent of  $\text{I}^-$  will be greater than, less than, or equal to the amount calculated in part (e). Justify your answer.

The mass percent of $\text{I}^-$ will be the same. $\text{Pb}^{2+}(aq)$ was added in excess, ensuring that essentially no $\text{I}^-$ remained in solution. The additional water is removed by filtration and drying, leaving the same mass of dried precipitate.	1 point is earned for correct comparison with a valid justification.
--	--

**AP<sup>®</sup> CHEMISTRY**  
**2014 SCORING GUIDELINES**

**Question 1 (continued)**

(g) A student in another lab also wants to determine the  $I^-$  content of a KI tablet but does not have access to  $Pb(NO_3)_2$ . However, the student does have access to  $0.20\ M\ AgNO_3$ , which reacts with  $I^-(aq)$  to produce  $AgI(s)$ . The value of  $K_{sp}$  for  $AgI$  is  $8.5 \times 10^{-17}$ .

(i) Will the substitution of  $AgNO_3$  for  $Pb(NO_3)_2$  result in the precipitation of the  $I^-$  ion from solution? Justify your answer.

Yes. Addition of an excess of $0.20\ M\ AgNO_3(aq)$ will precipitate all of the $I^-$ ion present in the solution because $AgI$ is insoluble, as evidenced by its low value of $K_{sp}$ .	1 point is earned for the correct answer with a valid justification.
---	--

(ii) The student only has access to one KI tablet and a balance that can measure to the nearest  $0.01\ g$ . Will the student be able to determine the mass of  $AgI$  produced to three significant figures? Justify your answer.

No. If masses can be measured to $\pm 0.01\ g$ , then the mass of the dry $AgI(s)$ precipitate (which is less than $1\ g$ ) will be known to only two significant figures.	1 point is earned for a correct answer with a valid justification.
--	--

**AP<sup>®</sup> CHEMISTRY**  
**2014 SCORING GUIDELINES**

**Question 2**  
**(10 points)**

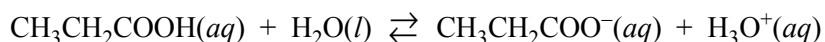

Propanoic acid,  $\text{CH}_3\text{CH}_2\text{COOH}$ , is a carboxylic acid that reacts with water according to the equation above. At  $25^\circ\text{C}$  the pH of a 50.0 mL sample of 0.20 M  $\text{CH}_3\text{CH}_2\text{COOH}$  is 2.79.

- (a) Identify a Brønsted-Lowry conjugate acid-base pair in the reaction. Clearly label which is the acid and which is the base.

$\text{CH}_3\text{CH}_2\text{COOH}$ and $\text{CH}_3\text{CH}_2\text{COO}^-$ <i>acid</i> <i>base</i> OR $\text{H}_3\text{O}^+$ and $\text{H}_2\text{O}$ <i>acid</i> <i>base</i>	1 point is earned for writing (or naming) either of the Brønsted-Lowry conjugate acid-base pairs with a clear indication of which is the acid and which is the base.
---	--

- (b) Determine the value of  $K_a$  for propanoic acid at  $25^\circ\text{C}$ .

$[\text{H}_3\text{O}^+] = 10^{-\text{pH}} = 10^{-2.79} = 1.6 \times 10^{-3} M$ $[\text{CH}_3\text{CH}_2\text{COO}^-] = [\text{H}_3\text{O}^+]$ AND $[\text{CH}_3\text{CH}_2\text{COOH}] = 0.20 M - [\text{H}_3\text{O}^+]$ , OR $[\text{CH}_3\text{CH}_2\text{COOH}] \approx 0.20 M$ (state or assume that $[\text{H}_3\text{O}^+] \ll 0.20 M$ ) $K_a = \frac{[\text{CH}_3\text{CH}_2\text{COO}^-][\text{H}_3\text{O}^+]}{[\text{CH}_3\text{CH}_2\text{COOH}]} = \frac{(1.6 \times 10^{-3} M)^2}{0.20 M} = 1.3 \times 10^{-5}$	1 point is earned for correctly solving for $[\text{H}_3\text{O}^+]$ . 1 point is earned for the $K_a$ expression for propanoic acid OR 1 point is earned for substituting values into the $K_a$ expression. 1 point is earned for correctly solving for the value of $K_a$ .
---	---

- (c) For each of the following statements, determine whether the statement is true or false. In each case, explain the reasoning that supports your answer.

- (i) The pH of a solution prepared by mixing the 50.0 mL sample of 0.20 M  $\text{CH}_3\text{CH}_2\text{COOH}$  with a 50.0 mL sample of 0.20 M NaOH is 7.00.

False. The conjugate base of a weak acid undergoes hydrolysis (see equation below) at equivalence to form a solution with a $\text{pH} > 7$ . $(\text{CH}_3\text{CH}_2\text{COO}^- + \text{H}_2\text{O} \rightleftharpoons \text{CH}_3\text{CH}_2\text{COOH} + \text{OH}^-)$	1 point is earned for noting that the statement is false AND providing a supporting explanation.
---	--

**AP<sup>®</sup> CHEMISTRY**  
**2014 SCORING GUIDELINES**

**Question 2 (continued)**

- (ii) If the pH of a hydrochloric acid solution is the same as the pH of a propanoic acid solution, then the molar concentration of the hydrochloric acid solution must be less than the molar concentration of the propanoic acid solution.

True. HCl is a strong acid that ionizes completely. Fewer moles of HCl are needed to produce the same $[H_3O^+]$ as the propanoic acid solution, which only partially ionizes.	1 point is earned for noting that the statement is true and providing a supporting explanation.
--	---

A student is given the task of determining the concentration of a propanoic acid solution of unknown concentration. A 0.173 M NaOH solution is available to use as the titrant. The student uses a 25.00 mL volumetric pipet to deliver the propanoic acid solution to a clean, dry flask. After adding an appropriate indicator to the flask, the student titrates the solution with the 0.173 M NaOH, reaching the end point after 20.52 mL of the base solution has been added.

- (d) Calculate the molarity of the propanoic acid solution.

<p>Let <math>x</math> = moles of propanoic acid</p> <p>then <math>x = (0.02052 \text{ L NaOH}) \times \frac{0.173 \text{ mol NaOH}}{1 \text{ L NaOH}} \times \frac{1 \text{ mol acid}}{1 \text{ mol NaOH}}</math></p> <p style="margin-left: 2em;"><math>= 3.55 \times 10^{-3} \text{ mol propanoic acid}</math></p> <p style="margin-left: 2em;"><math>\frac{3.55 \times 10^{-3} \text{ mol acid}}{0.02500 \text{ L acid}} = 0.142 \text{ M}</math></p> <p>OR</p> <p>Since <math>CH_3CH_2COOH</math> is monoprotic and, at the equivalence point, moles <math>H^+ = \text{moles } OH^-</math>, then</p> $M_A V_A = M_B V_B$ $M_A = \frac{M_B V_B}{V_A} = \frac{(0.173 \text{ M NaOH})(20.52 \text{ mL NaOH})}{25.00 \text{ mL acid}} = 0.142 \text{ M}$	<p>1 point is earned for correctly calculating the number of moles of acid that reacted at the equivalence point.</p> <p>1 point is earned for the correct molarity of acid.</p>
--	--

- (e) The student is asked to redesign the experiment to determine the concentration of a butanoic acid solution instead of a propanoic acid solution. For butanoic acid the value of  $pK_a$  is 4.83. The student claims that a different indicator will be required to determine the equivalence point of the titration accurately. Based on your response to part (b), do you agree with the student's claim? Justify your answer.

**AP<sup>®</sup> CHEMISTRY**  
**2014 SCORING GUIDELINES**

**Question 2 (continued)**

<p><u>Disagree</u> with the student's claim</p> <p>From part (b) above, <math>pK_a</math> for propanoic acid is <math>\log(1.3 \times 10^{-5}) = 4.89</math>. Because 4.83 is so close to 4.89, the pH at the equivalence point in the titration of butanoic acid should be close enough to the pH in the titration of propanoic acid to make the original indicator appropriate for the titration of butanoic acid.</p>	<p>1 point is earned for disagreeing with the student's claim and making a valid justification using <math>pK_a</math>, <math>K_a</math>, or pH arguments.</p> <p>1 point is earned for numerically comparing either: the two <math>pK_a</math> values, the two <math>K_a</math> values, or the two pH values at the equivalence point.</p>
--	---



**AP<sup>®</sup> CHEMISTRY**  
**2014 SCORING GUIDELINES**

**Question 3**  
**(10 points)**

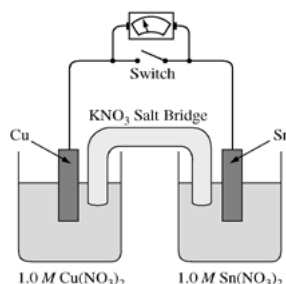

A student is given a standard galvanic cell, represented above, that has a Cu electrode and a Sn electrode. As current flows through the cell, the student determines that the Cu electrode increases in mass and the Sn electrode decreases in mass.

- (a) Identify the electrode at which oxidation is occurring. Explain your reasoning based on the student's observations.

<p>Since the Sn electrode is losing mass, Sn atoms must be forming <math>\text{Sn}^{2+}(\text{aq})</math>. This process is oxidation.</p> <p>OR</p> <p>because the cell operates, <math>E^\circ</math> must be positive and, based on the <math>E^\circ</math> values from the table, it must be Sn that is oxidized.</p>	<p>1 point is earned for the correct answer with justification.</p>
---	---

- (b) As the mass of the Sn electrode decreases, where does the mass go?

<p>The atoms on the Sn electrode are going into the solution as <math>\text{Sn}^{2+}</math> ions.</p>	<p>1 point is earned for the correct answer.</p>
---	--

- (c) In the expanded view of the center portion of the salt bridge shown in the diagram below, draw and label a particle view of what occurs in the salt bridge as the cell begins to operate. Omit solvent molecules and use arrows to show the movement of particles.

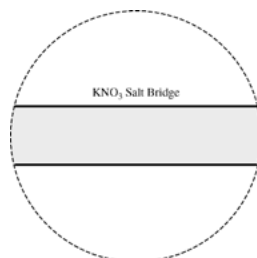

<p>The response should show at least one <math>\text{K}^+</math> ion moving toward the Cu compartment on the left and at least one <math>\text{NO}_3^-</math> ion moving in the opposite direction.</p>	<p>1 point is earned for correct representation of both <math>\text{K}^+</math> and <math>\text{NO}_3^-</math> ions. (Including free electrons loses this point.)</p> <p>1 point is earned for correctly indicating the direction of movement of both ions.</p>
---	---

**AP<sup>®</sup> CHEMISTRY**  
**2014 SCORING GUIDELINES**

**Question 3 (continued)**

(d) A nonstandard cell is made by replacing the 1.0 *M* solutions of  $\text{Cu}(\text{NO}_3)_2$  and  $\text{Sn}(\text{NO}_3)_2$  in the standard cell with 0.50 *M* solutions of  $\text{Cu}(\text{NO}_3)_2$  and  $\text{Sn}(\text{NO}_3)_2$ . The volumes of solutions in the nonstandard cell are identical to those in the standard cell.

(i) Is the cell potential of the nonstandard cell greater than, less than, or equal to the cell potential of the standard cell? Justify your answer.

It is the same. In the cell reaction $Q = \frac{[\text{Sn}^{2+}]}{[\text{Cu}^{2+}]}$ , and the concentrations of $\text{Sn}^{2+}$ and $\text{Cu}^{2+}$ are equal to each other in both cases.	1 point is earned for the correct answer with justification.
---	--

(ii) Both the standard and nonstandard cells can be used to power an electronic device. Would the nonstandard cell power the device for the same time, a longer time, or a shorter time as compared with the standard cell? Justify your answer.

The nonstandard cell would power the device for a shorter time because the supply of $\text{Cu}^{2+}$ ions will be exhausted more quickly. <p style="text-align: center;">OR</p> The nonstandard cell would power the device for a shorter time because the reaction will reach $E = 0$ more quickly.	1 point is earned for the correct answer with justification.
--	--

(e) In another experiment, the student places a new Sn electrode into a fresh solution of 1.0 *M*  $\text{Cu}(\text{NO}_3)_2$ .

Half-Reaction	$E^\circ$ (V)
$\text{Cu}^+ + e^- \rightarrow \text{Cu}(s)$	0.52
$\text{Cu}^{2+} + 2e^- \rightarrow \text{Cu}(s)$	0.34
$\text{Sn}^{4+} + 2e^- \rightarrow \text{Sn}^{2+}$	0.15
$\text{Sn}^{2+} + 2e^- \rightarrow \text{Sn}(s)$	-0.14

(i) Using information from the table above, write a net-ionic equation for the reaction between the Sn electrode and the  $\text{Cu}(\text{NO}_3)_2$  solution that would be thermodynamically favorable. Justify that the reaction is thermodynamically favorable.

**AP<sup>®</sup> CHEMISTRY**  
**2014 SCORING GUIDELINES**

**Question 3 (continued)**

$\text{Cu}^{2+}(\text{aq}) + \text{Sn}(\text{s}) \rightarrow \text{Cu}(\text{s}) + \text{Sn}^{2+}(\text{aq})$ <p><math>E^\circ</math> is positive (<math>0.34 \text{ V} + 0.14 \text{ V} = 0.48 \text{ V}</math>), therefore the reaction is thermodynamically favorable.</p> <p>OR</p> <p>The cell observations from earlier parts of the question are evidence that the Sn is oxidized and Cu is reduced, therefore <math>E^\circ</math> must be positive.</p>	<p>1 point is earned for the correct net-ionic equation.</p> <p>1 point is earned for a correct justification (unit not needed in calculation).</p>
--	---

(ii) Calculate the value of  $\Delta G^\circ$  for the reaction. Include units with your answer.

$\Delta G^\circ = -nFE^\circ$ $\Delta G^\circ = -\frac{2 \text{ mol } e^-}{\text{mol}_{\text{rxn}}} \times \frac{96,485 \text{ C}}{\text{mol } e^-} \times \frac{0.48 \text{ J}}{\text{C}} = -93,000 \text{ J/mol}_{\text{rxn}} = -93 \text{ kJ/mol}_{\text{rxn}}$	<p>1 point is earned for the correct number of electrons.</p> <p>1 point is earned for the correct answer with unit.</p>
--	--

**AP<sup>®</sup> CHEMISTRY**  
**2014 SCORING GUIDELINES**

**Question 4**  
**(4 points)**

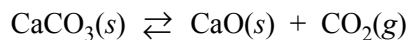

When heated, calcium carbonate decomposes according to the equation above. In a study of the decomposition of calcium carbonate, a student added a 50.0 g sample of powdered  $\text{CaCO}_3(s)$  to a 1.00 L rigid container. The student sealed the container, pumped out all the gases, then heated the container in an oven at 1100 K. As the container was heated, the total pressure of the  $\text{CO}_2(g)$  in the container was measured over time. The data are plotted in the graph below.

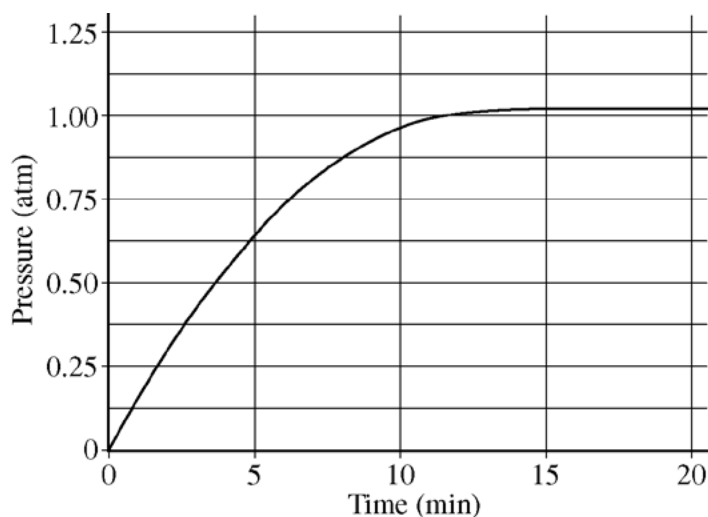

The student repeated the experiment, but this time the student used a 100.0 g sample of powdered  $\text{CaCO}_3(s)$ . In this experiment, the final pressure in the container was 1.04 atm, which was the same final pressure as in the first experiment.

(a) Calculate the number of moles of  $\text{CO}_2(g)$  present in the container after 20 minutes of heating.

$PV = nRT$ $\frac{PV}{RT} = n = \frac{(1.04 \text{ atm})(1.00 \text{ L})}{(0.0821 \frac{\text{L atm}}{\text{mol K}})(1100 \text{ K})} = 0.0115 \text{ mol CO}_2$	1 point is earned for the proper setup using the ideal gas law and an answer that is consistent with the setup.
--	---

**AP<sup>®</sup> CHEMISTRY**  
**2014 SCORING GUIDELINES**

**Question 4 (continued)**

- (b) The student claimed that the final pressure in the container in each experiment became constant because all of the  $\text{CaCO}_3(s)$  had decomposed. Based on the data in the experiments, do you agree with this claim? Explain.

<p>Do not agree with claim</p> <p>Explanation I: In experiment 1, the moles of <math>\text{CaCO}_3 = 50.0 \text{ g}/100.09 \text{ g/mol} = 0.500 \text{ mol CaCO}_3</math>. If the reaction had gone to completion, 0.500 mol of <math>\text{CO}_2</math> would have been produced. From part (a) only 0.0115 mol was produced. Hence, the student's claim was false.</p> <p>Explanation II: The two different experiments (one with 50.0 g of <math>\text{CaCO}_3</math> and one with 100.0 g of <math>\text{CaCO}_3</math>) reached the same constant, final pressure of 1.04 atm. Since increasing the amount of reactant did not produce more product, there is no way that all of the <math>\text{CaCO}_3</math> reacted. Instead, an equilibrium condition has been achieved and there must be some solid <math>\text{CaCO}_3</math> in the container.</p>	<p>1 point is earned for disagreement with the claim <u>and</u> for a correct justification using stoichiometry or a discussion of the creation of an equilibrium condition.</p>
--	--

- (c) After 20 minutes some  $\text{CO}_2(g)$  was injected into the container, initially raising the pressure to 1.5 atm. Would the final pressure inside the container be less than, greater than, or equal to 1.04 atm? Explain your reasoning.

<p>The final pressure would be equal to 1.04 atm. Equilibrium was reached in both experiments; the equilibrium pressure at this temperature is 1.04 atm. As the reaction shifts toward the reactant, the amount of <math>\text{CO}_2(g)</math> in the container will decrease until the pressure returns to 1.04 atm.</p>	<p>1 point is earned for the correct answer with justification.</p>
---	---

- (d) Are there sufficient data obtained in the experiments to determine the value of the equilibrium constant,  $K_p$ , for the decomposition of  $\text{CaCO}_3(s)$  at 1100 K? Justify your answer.

**AP<sup>®</sup> CHEMISTRY**  
**2014 SCORING GUIDELINES**

**Question 4 (continued)**

Yes. For the equilibrium reaction represented by the chemical equation in this problem, at a given temperature the equilibrium pressure of  $\text{CO}_2$  determines the equilibrium constant. Since the measured pressure of  $\text{CO}_2$  is also the equilibrium pressure of  $\text{CO}_2$ ,  $K_p = P_{\text{CO}_2} = 1.04$ .

Note: If the response in part (b) indicates “yes”, that all of the  $\text{CaCO}_3(s)$  had decomposed, then the point can be earned by stating that the system did not reach equilibrium in either experiment and hence the value of  $K_p$  cannot be calculated from the data.

1 point is earned for correct explanation that is consistent with the student’s answer to part (b).

**AP<sup>®</sup> CHEMISTRY**  
**2014 SCORING GUIDELINES**

**Question 5**  
**(4 points)**

Nonmetal	C	N	O	Ne	Si	P	S	Ar
Formula of Compound	CF <sub>4</sub>	NF <sub>3</sub>	OF <sub>2</sub>	No compound	SiF <sub>4</sub>	PF <sub>3</sub>	SF <sub>2</sub>	No compound

Some binary compounds that form between fluorine and various nonmetals are listed in the table above. A student examines the data in the table and poses the following hypothesis: the number of F atoms that will bond to a nonmetal is always equal to 8 minus the number of valence electrons in the nonmetal atom.

- (a) Based on the student's hypothesis, what should be the formula of the compound that forms between chlorine and fluorine?

ClF	1 point is earned for the correct formula.
-----	--

- (b) In an attempt to verify the hypothesis, the student researches the fluoride compounds of the other halogens and finds the formula ClF<sub>3</sub>. In the box below, draw a complete Lewis electron-dot diagram for a molecule of ClF<sub>3</sub>.

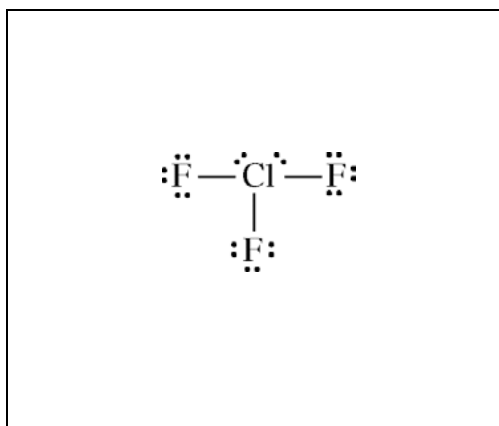

See diagram above.	1 point is earned for a central Cl atom surrounded by three bonding pairs with F atoms and two nonbonding (lone) pairs of electrons. F atoms must have three nonbonding pairs each. Electron pairs can be depicted as dots or line segments.
--------------------	--

**AP<sup>®</sup> CHEMISTRY**  
**2014 SCORING GUIDELINES**

**Question 5 (continued)**

- (c) Two possible geometric shapes for the  $\text{ClF}_3$  molecule are trigonal planar and T-shaped. The student does some research and learns that the molecule has a dipole moment. Which of the two shapes is consistent with the fact that the  $\text{ClF}_3$  molecule has a dipole moment? Justify your answer in terms of bond polarity and molecular structure.

The molecule is T-shaped because a T-shaped structure is asymmetric with dipoles that do not cancel out, but produce a net dipole (i.e., a polar molecule).

OR

because, if the molecule had a trigonal planar structure, the molecule would be symmetric with dipoles that cancel out and produce a net dipole of zero (i.e., a nonpolar molecule), which is not consistent with the observation that the  $\text{ClF}_3$  molecule does have a dipole moment.

1 point is earned for indicating that the molecule is T-shaped with an acceptable explanation.

In an attempt to resolve the existence of the  $\text{ClF}_3$  molecule with the hypothesis stated above, the student researches the compounds that form between halogens and fluorine, and assembles the following list.

Halogen	Formula(s)
F	$\text{F}_2$
Cl	
Br	$\text{BrF}$ , $\text{BrF}_3$ , $\text{BrF}_5$
I	$\text{IF}$ , $\text{IF}_3$ , $\text{IF}_5$ , $\text{IF}_7$

- (d) Based on concepts of atomic structure and periodicity, propose a modification to the student's previous hypothesis to account for the compounds that form between halogens and fluorine.

An acceptable hypothesis (descriptive or formulaic) must include the following ideas:

1. Atomic Structure: e.g., odd number of F atoms
2. Periodicity: e.g., as the atomic number of the central halogen atom increases, the number of F atoms increases.

1 point is earned for an acceptably modified hypothesis that addresses both atomic structure and periodicity.



**AP<sup>®</sup> CHEMISTRY**  
**2014 SCORING GUIDELINES**

**Question 6**  
**(4 points)**

A student places a mixture of plastic beads consisting of polypropylene (PP) and polyvinyl chloride (PVC) in a 1.0 L beaker containing distilled water. After stirring the contents of the beaker vigorously, the student observes that the beads of one type of plastic sink to the bottom of the beaker and the beads of the other type of plastic float on the water. The chemical structures of PP and PVC are represented by the diagrams below, which show segments of each polymer.

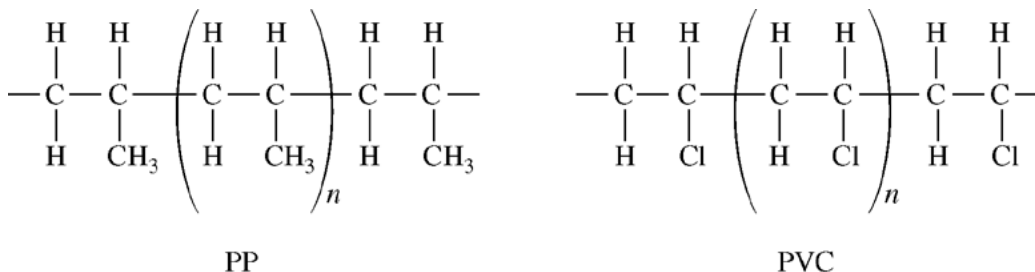

- (a) Given that the spacing between polymer chains in PP and PVC is similar, the beads that sink are made of which polymer? Explain.

The PVC beads sink. The spacing between chains is similar, but a Cl atom has a greater mass than CH<sub>3</sub>.

1 point is earned for the correct polymer with a correct explanation.

PP is synthesized from propene, C<sub>3</sub>H<sub>6</sub>, and PVC is synthesized from vinyl chloride, C<sub>2</sub>H<sub>3</sub>Cl. The structures of the molecules are shown below.

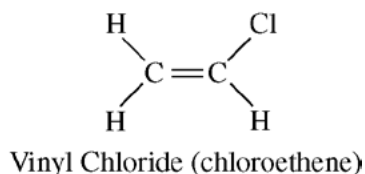
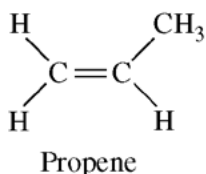

- (b) The boiling point of liquid propene (226 K) is lower than the boiling point of liquid vinyl chloride (260 K). Account for this difference in terms of the types and strengths of intermolecular forces present in each liquid.

Both substances have dipole-dipole interactions and London dispersion forces (or propene is essentially nonpolar with only LDFs while vinyl chloride has both LDFs and dipole-dipole forces). Propene contains a CH<sub>3</sub> group, but vinyl chloride contains a Cl atom. Vinyl chloride thus has a larger electron cloud, is more polarizable, and has a larger dipole moment. Thus intermolecular attractions are stronger in vinyl chloride, which results in it having the higher boiling point.

1 point is earned for a discussion of intermolecular forces and for a comparison of their relative strengths.

**AP<sup>®</sup> CHEMISTRY**  
**2014 SCORING GUIDELINES**

**Question 6 (continued)**

In a separate experiment, the student measures the enthalpies of combustion of propene and vinyl chloride. The student determines that the combustion of 2.00 mol of vinyl chloride releases 2300 kJ of energy, according to the equation below.

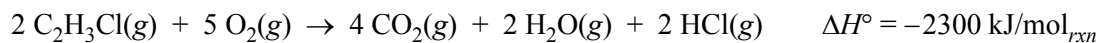

of propene releases more, less, or the same amount of energy that 2.00 mol of vinyl chloride releases. Justify your answer with a calculation. The balanced equation for the combustion of 2.00 mol of propene is  $2 \text{C}_3\text{H}_6(g) + 9 \text{O}_2(g) \rightarrow 6 \text{CO}_2(g) + 6 \text{H}_2\text{O}(g)$ .

Substance	$\text{C}_2\text{H}_3\text{Cl}(g)$	$\text{C}_3\text{H}_6(g)$	$\text{CO}_2(g)$	$\text{H}_2\text{O}(g)$	$\text{HCl}(g)$	$\text{O}_2(g)$
Standard Enthalpy of Formation (kJ/mol)	37	21	-394	-242	-92	0

$\Delta H^\circ = 6(-394) + 6(-242) - 2(21) = -3858 \text{ kJ/mol}_{rxn}$ <p>The combustion of 2.00 mol of propene releases more energy.</p>	<p>1 point is earned for the calculation of the enthalpy of combustion of propene.</p> <p>1 point is earned for the comparison of propene to vinyl chloride that is consistent with the calculated value.</p>
--	---

**AP<sup>®</sup> CHEMISTRY**  
**2014 SCORING GUIDELINES**

**Question 7**  
**(4 points)**

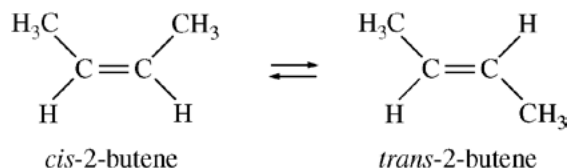

The half-life ( $t_{1/2}$ ) of the catalyzed isomerization of *cis*-2-butene gas to produce *trans*-2-butene gas, represented above, was measured under various conditions, as shown in the table below.

Trial Number	Initial $P_{cis\text{-}2\text{-butene}}$ (torr)	$V$ (L)	$T$ (K)	$t_{1/2}$ (s)
1	300.	2.00	350.	100.
2	600.	2.00	350.	100.
3	300.	4.00	350.	100.
4	300.	2.00	365	50.

(a) The reaction is first order. Explain how the data in the table are consistent with a first-order reaction.

For a first-order reaction, the half-life is independent of reactant concentration (or pressure) at constant  $T$ , as shown in trials 1, 2, and 3.

1 point is earned for a correct explanation.

(b) Calculate the rate constant,  $k$ , for the reaction at 350. K. Include appropriate units with your answer.

$$k = \frac{0.693}{t_{1/2}} = \frac{0.693}{100. \text{ s}} = 0.00693 \text{ s}^{-1}$$

1 point is earned for correct numerical answer with units.

(c) Is the initial rate of the reaction in trial 1 greater than, less than, or equal to the initial rate in trial 2? Justify your answer.

The initial rate in trial 1 is less than that in trial 2 because rate =  $k[\textit{cis}\text{-}2\text{-butene}]$  or rate =  $kP_{\textit{cis}\text{-}2\text{-butene}}$  (with reference to values from both trials).

OR

because the initial concentration of *cis*-2-butene in trial 1 is less than that in trial 2 and  $k$  is constant.

1 point is earned for the correct answer with justification.

(d) The half-life of the reaction in trial 4 is less than the half-life in trial 1. Explain why, in terms of activation energy.

The temperature is higher in trial 4, meaning that the  $KE_{\text{avg}}$  of the molecules is greater. Consequently, in this trial a greater fraction of collisions have sufficient energy to overcome the activation energy barrier, thus the rate is greater.

1 point is earned for a correct answer with justification.

---

## Scoring Worksheet

The following provides a scoring worksheet and conversion table used for calculating a composite score of the exam.

## 2014 AP Chemistry Scoring Worksheet

### Section I: Multiple Choice

$$\frac{\text{Number Correct}}{\text{(out of 50)}} \times 1.0000 = \frac{\text{Weighted Section I Score}}{\text{(Do not round)}}$$

### Section II: Free Response

$$\text{Question 1 } \frac{\text{_____}}{\text{(out of 10)}} \times 1.0869 = \frac{\text{_____}}{\text{(Do not round)}}$$

$$\text{Question 2 } \frac{\text{_____}}{\text{(out of 10)}} \times 1.0869 = \frac{\text{_____}}{\text{(Do not round)}}$$

$$\text{Question 3 } \frac{\text{_____}}{\text{(out of 10)}} \times 1.0869 = \frac{\text{_____}}{\text{(Do not round)}}$$

$$\text{Question 4 } \frac{\text{_____}}{\text{(out of 4)}} \times 1.0869 = \frac{\text{_____}}{\text{(Do not round)}}$$

$$\text{Question 5 } \frac{\text{_____}}{\text{(out of 4)}} \times 1.0869 = \frac{\text{_____}}{\text{(Do not round)}}$$

$$\text{Question 6 } \frac{\text{_____}}{\text{(out of 4)}} \times 1.0869 = \frac{\text{_____}}{\text{(Do not round)}}$$

$$\text{Question 7 } \frac{\text{_____}}{\text{(out of 4)}} \times 1.0869 = \frac{\text{_____}}{\text{(Do not round)}}$$

$$\text{Sum} = \frac{\text{_____}}{\text{Weighted Section II Score (Do not round)}}$$

### Composite Score

$$\frac{\text{Weighted Section I Score}}{\text{_____}} + \frac{\text{Weighted Section II Score}}{\text{_____}} = \frac{\text{Composite Score (Round to nearest whole number)}}{\text{_____}}$$

AP Score Conversion Chart  
Chemistry

Composite Score Range	AP Score
72-100	5
58-71	4
42-57	3
27-41	2
0-26	1

# AP Chemistry

---

## **The College Board**

The College Board is a mission-driven not-for-profit organization that connects students to college success and opportunity. Founded in 1900, the College Board was created to expand access to higher education. Today, the membership association is made up of over 6,000 of the world's leading educational institutions and is dedicated to promoting excellence and equity in education. Each year, the College Board helps more than seven million students prepare for a successful transition to college through programs and services in college readiness and college success — including the SAT<sup>®</sup> and the Advanced Placement Program<sup>®</sup>. The organization also serves the education community through research and advocacy on behalf of students, educators, and schools. The College Board is committed to the principles of excellence and equity, and that commitment is embodied in all of its programs, services, activities, and concerns.